

Surface Raceway / Aluminum SWA3218

SnapWay™ Fittings

Manufactured by MonoSystems, Inc.

90° EXTERNAL ELBOW

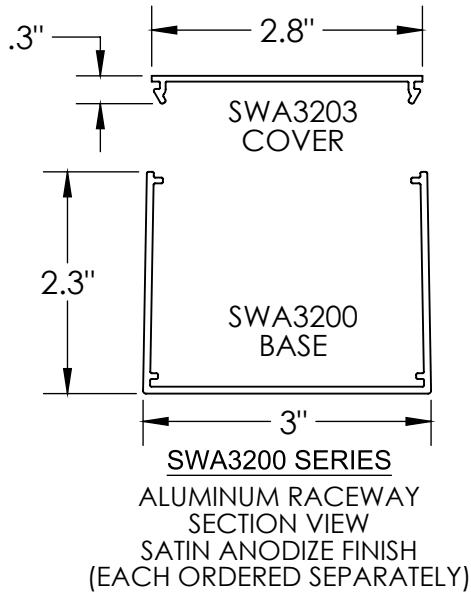

Assembly Instructions

- 1.) Connect SWA3218 to SWA3200 base sections using SWA3202 (ordered separately) couplings (2 places TYP).
- 2.) Secure elbow to base sections by tightening 8-2 x 3/16" screws (8 places TYP).
- 3.) Snap cover into place.

Material

#6063-T6 Extruded Aluminum. Nominal Wall Thickness 0.060".
Satin Anodized Finish.



UL LISTED
FILE: E167318

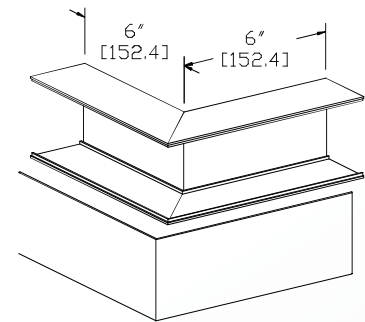

SWA3218

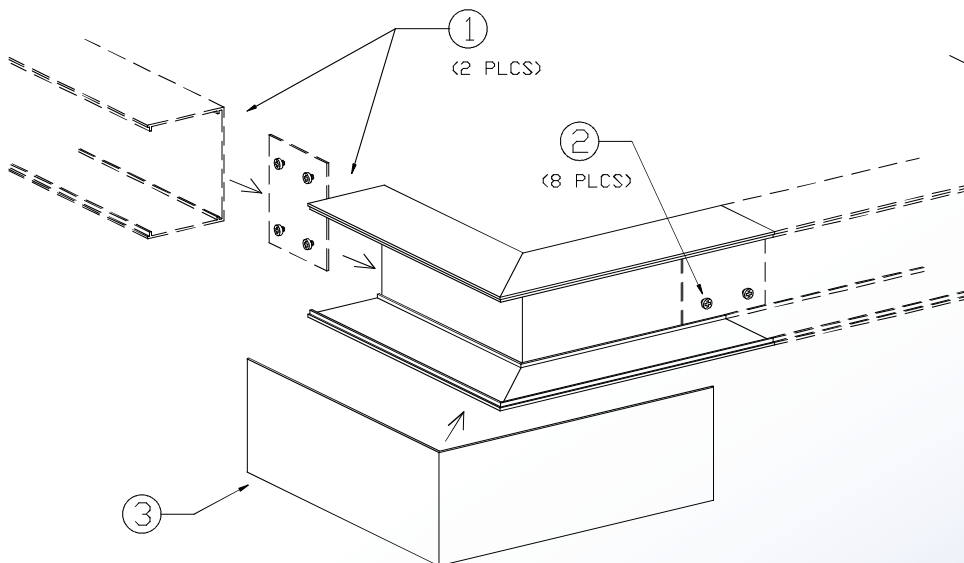

4 International Drive
Rye Brook, NY 10573
Toll Free: 1 888.764.7681
Phone: 914.934.2075
Fax: 914.934.2190
MonoSystems.com

