

Surface Raceway / Aluminum SWA2216

SnapWay™ Fittings

Manufactured by MonoSystems, Inc.

"L" ADD-ON HORIZONTAL INTERNAL 90° ELBOW

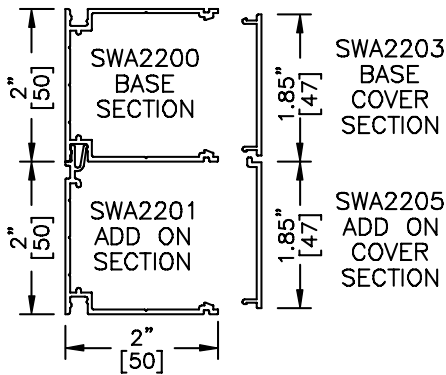

SWA2200 SERIES RACEWAY
SECTION VIEW
EACH ORDERED SEPARATELY
MATL.: .06" [1.5] THICK #6063-T6 ALUM.
SCALE: NONE

Assembly Instructions

- 1.) Connect SWA2216 "L" add-on horizontal internal 90° elbow body unit to existing SWA2200 base sections using provided SWA2202 couplings. Secure with four 6-32 x 1/8" screws (2 places TYP).
- 2.) Snap SWA2216 "L" add-on horizontal 90° internal elbow cover unit into each SWA2216 "L" add-on horizontal internal 90° elbow body unit as shown ensuring the secure fit of each cover leg into each body unit interlock (2 places TYP).

Scale: None



UL LISTED
FILE: E167318

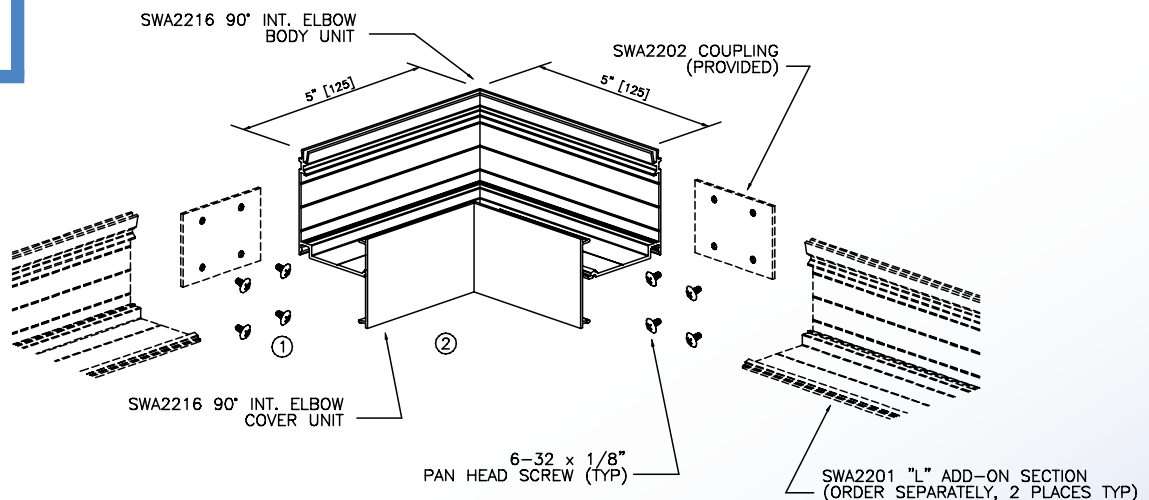

4 International Drive
Rye Brook, NY 10573
Toll Free: 1 888.764.7681
Phone: 914.934.2075
Fax: 914.934.2190
MonoSystems.com

