

Cable Tray / Ladder Tray XX-X010-PR

PowerTray™ Accessories
Manufactured by MonoSystems, Inc.



VERTICAL PIVOT CONNECTOR

Notes

- 1.) Ordered as pairs. Includes 3/8" pivot and 3/8" tray mounting hardware. Orient as desired and tighten hardware. Recommended torque for 3/8" fasteners: 35 ft-lbs [47.5 N-m]
- 2.) Tray must be supported within 24" on both sides per NEMA VE2. Supports by others.
- 3.) Bonding jumper not required.
- 4.) Views for reference - do not scale.

ORDERING DATA EXAMPLE:

XH-X010-PR

TRAY MATERIAL

A = ALUMINUM
G = HDGAF
P = PRE-GALV STEEL

RAIL HEIGHT

4 = 4" HIGH
5 = 5" HIGH
6 = 6" HIGH
7 = 7" HIGH

SERIES

1 = "L" SERIES
2 = B,C,D,E SERIES

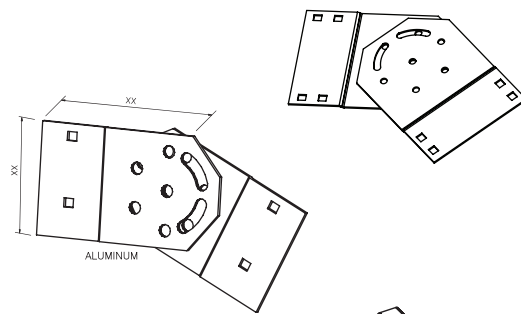
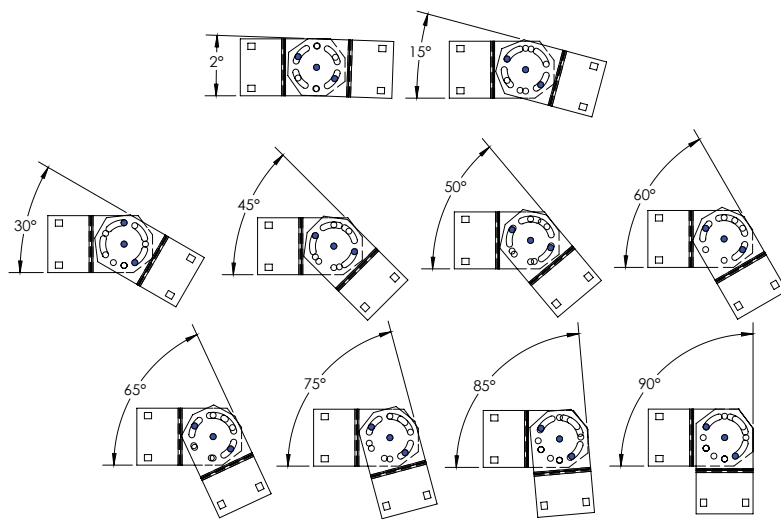

STEEL POWER-TRAY
(ORDERED SEPARATELY)

P6-2010-PR (SHOWN)
TRAY ATTACHMENT
HARDWARE PROVIDED

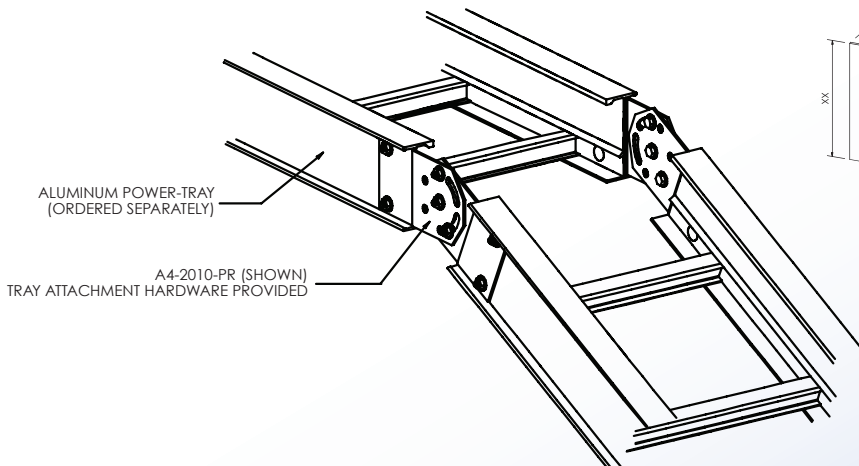
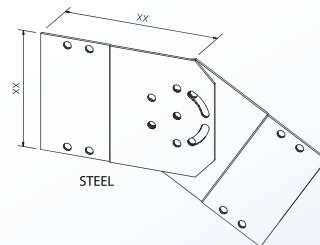
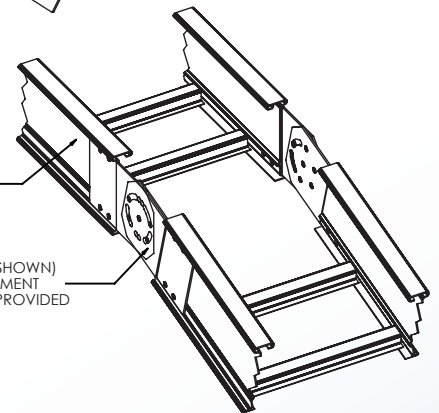

4 International Drive
Rye Brook, NY 10573
Toll Free: 1 888.764.7681
Phone: 914.934.2075
Fax: 914.934.2190
MonoSystems.com

