

Cable Tray / Channel Tray

SXX-XX-90VXX

Channel Tray Fittings
 Manufactured in the USA by MonoSystems, Inc.



90° Outside Vertical Bend

General Information

- 1.) Attach bend to channel tray using (1) supplied splice plate (SBX-104X) and provided 3/8" hardware.
- 2.) Recommended torque: for 3/8" fasteners 25-35 ft-lbs [33.9-47.5 N-m].
- 3.) Views for reference - do not scale.

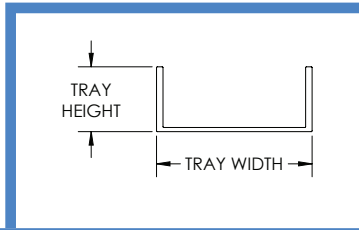
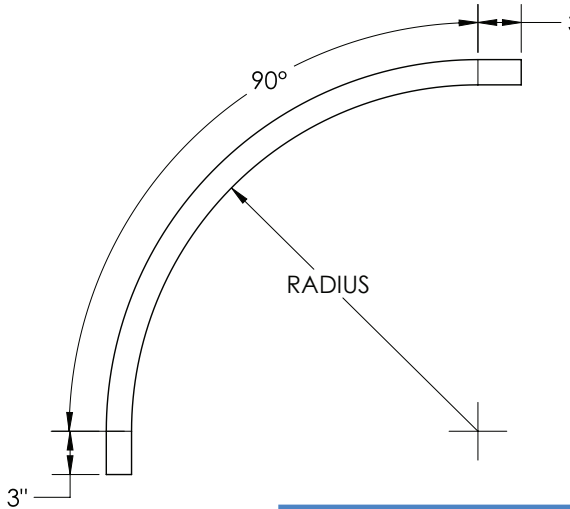

TRAY HEIGHT		TRAY WIDTH	
H		W	
IN.	MM.	IN.	MM.
1.25	32	3	76
1.75	44	4	101
1.75	44	6	152

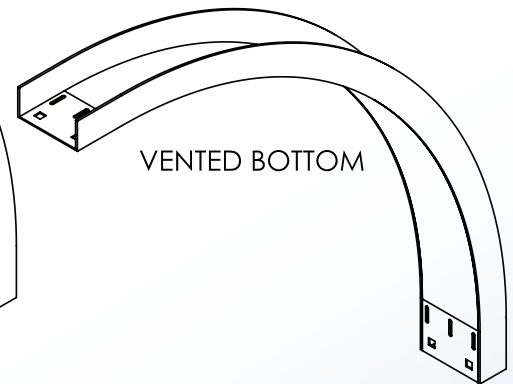
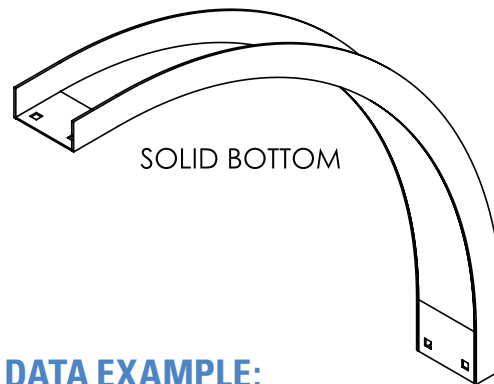

ORDERING DATA EXAMPLE:

SXX - XX - 90 OV XX

STYLE MATERIAL WIDTH ANGLE FITTING TYPE RADIUS

B = SOLID
 BOTTOM
 V = VENTED
 BOTTOM

A = ALUMINUM
 P = PREGALV STEEL
 G = HDGAF STEEL
 SS4 = STAINLESS STEEL 304
 SS6 = STAINLESS STEEL 316

03 = 3"
 04 = 4"
 06 = 6"

90°

OV = OUTSIDE
 VERTICAL
 BEND

12 = 12"
 24 = 24"
 36 = 36"
 48 = 48"

4 International Drive
 Rye Brook, NY 10573
 Toll Free: 1 888.764.7681
 Phone: 914.934.2075
 Fax: 914.934.2190
 MonoSystems.com

