

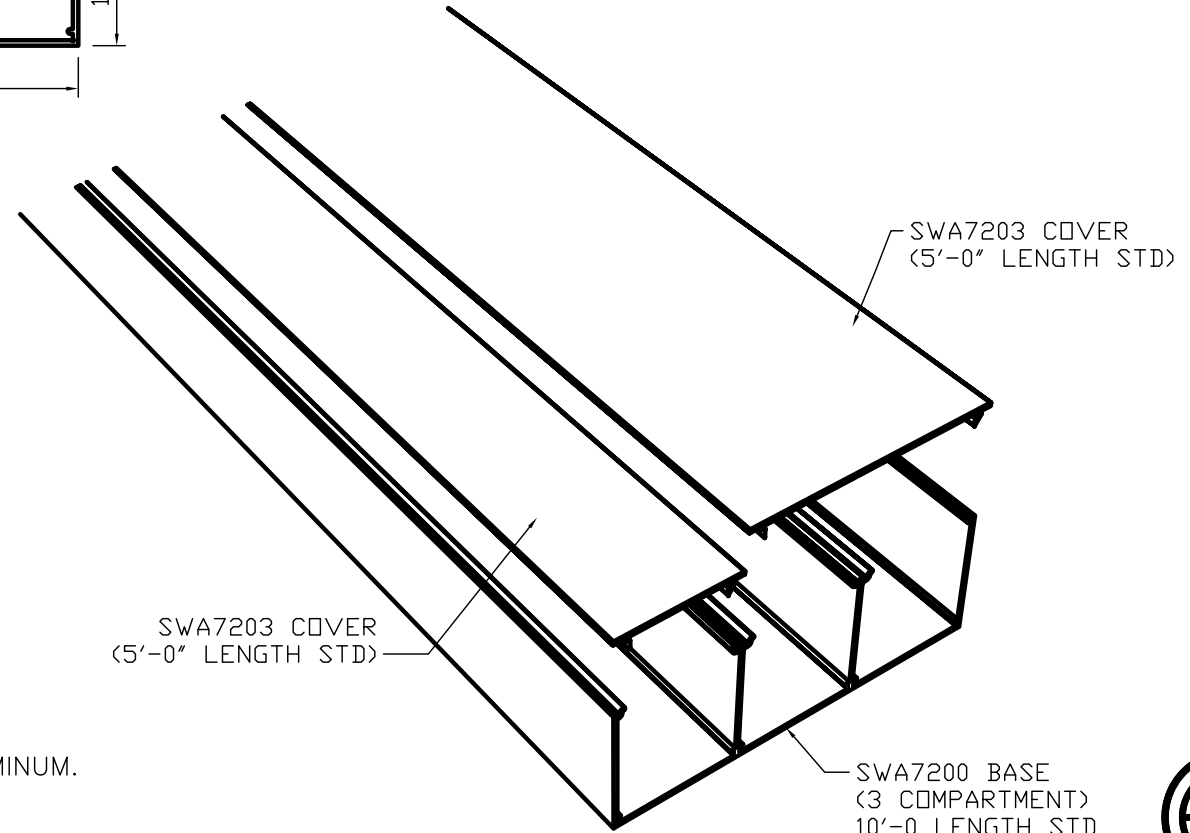

SWA7200 SERIES
ALUMINUM RACEWAY
SECTION VIEW
SATIN ANODIZED FINISH
(EACH ORDERED SEPARATELY)



MATERIAL: #6063-T6 EXTRUDED ALUMINUM.
NOMINAL WALL THICKNESS 0.075".
FINISH: SATIN ANODIZED



 MONO-SYSTEMS, INC. UNIQUE CABLE DISTRIBUTION SOLUTIONS		DRAWING TITLE: SWA7200 SERIES RACEWAY		DR. BY: JFM
		PROJECT: ALUMINUM SURFACE RACEWAY		APP'VD BY:
PART NUMBER CS-SWA7200	BUFFALO OFFICE: 180 HOPKINS STREET BUFFALO, NEW YORK 14220 PHONE: (716)-821-1344 FAX: (716)-821-1345	CORPORATE OFFICE: 4 INTERNATIONAL DRIVE RYE BROOK, NEW YORK 10573 PHONE: (914) 934-2075 FAX: (914) 934-2190	SCALE: NTS DATE: 12/30/2010	DWG. NO. CS-SWA7200 REVA

SWA7200 SERIES
SWA7202 - COUPLING

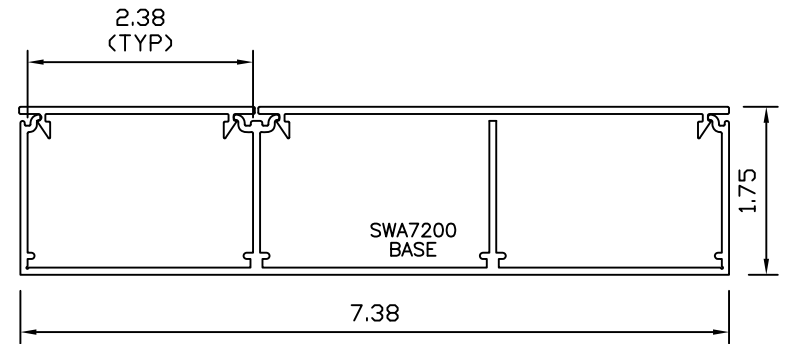

SWA7200 SERIES
ALUMINUM RACEWAY
SECTION VIEW
SATIN ANNOXIDIZED FINISH
(EACH ORDERED SEPARATELY)

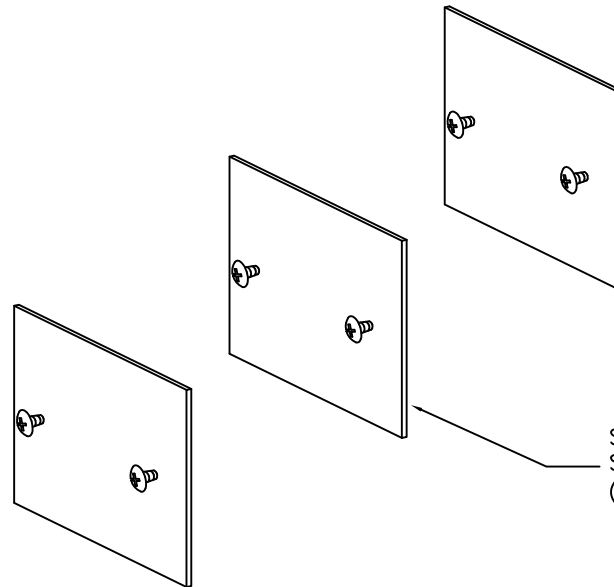

SWA7202 - COUPLING
SOLD IN SETS OF THREE AS SHOWN
(ASSY. HARDWARE INC.)



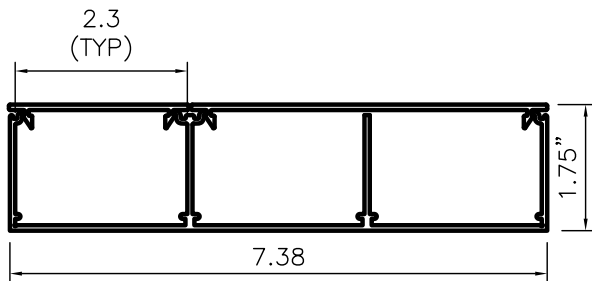

MONO-SYSTEMS, INC.
UNIQUE CABLE DISTRIBUTION SOLUTIONS
4 INTERNATIONAL DRIVE
RYE BROOK, NEW YORK 10573
PHONE: (914)-934-2075
FAX: (914)-934-2190

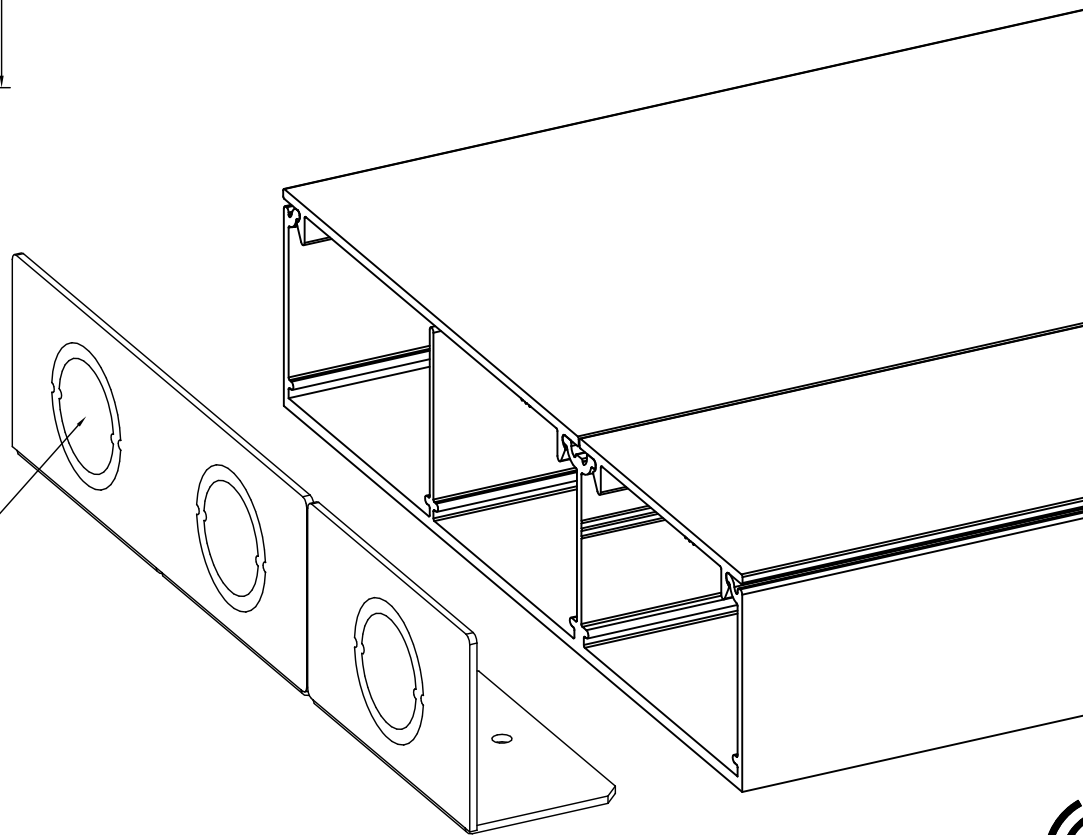

SWA7200 SERIES
ALUMINUM RACEWAY
SECTION VIEW
SATIN ANNOXIDIZED FINISH
(EACH ORDERED SEPARATELY)

1/2" & 3/4"
TRADE KO'S
(TYP)



 MONO-SYSTEMS, INC. UNIQUE CABLE DISTRIBUTION SOLUTIONS	DRAWING TITLE: SWA7200 SERIES RACEWAY BLANK / END FEED FITTING		DR. BY: JFM		
			APPV'D BY:		
PART NUMBER CS-SWA7204	BUFFALO OFFICE: 180 HOPKINS STREET BUFFALO, NEW YORK 14220 PHONE: (716)-821-1344 FAX: (716)-821-1345	CORPORATE OFFICE: 4 INTERNATIONAL DRIVE RYE BROOK, NEW YORK 10573 PHONE: (914) 934-2075 FAX: (914) 934-2190	PROJECT: ALUMINUM SURFACE RACEWAY	SCALE: NTS	DWG. NO. CS-SWA7204 REVO
			DATE: 12/30/2010		

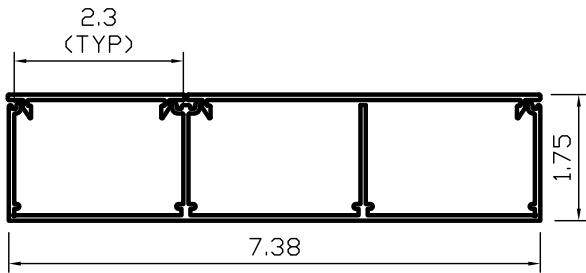

SWA7200 SERIES
ALUMINUM RACEWAY
SECTION VIEW
SATIN ANODIZED FINISH
(EACH ORDERED SEPARATELY)

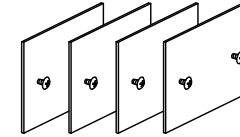
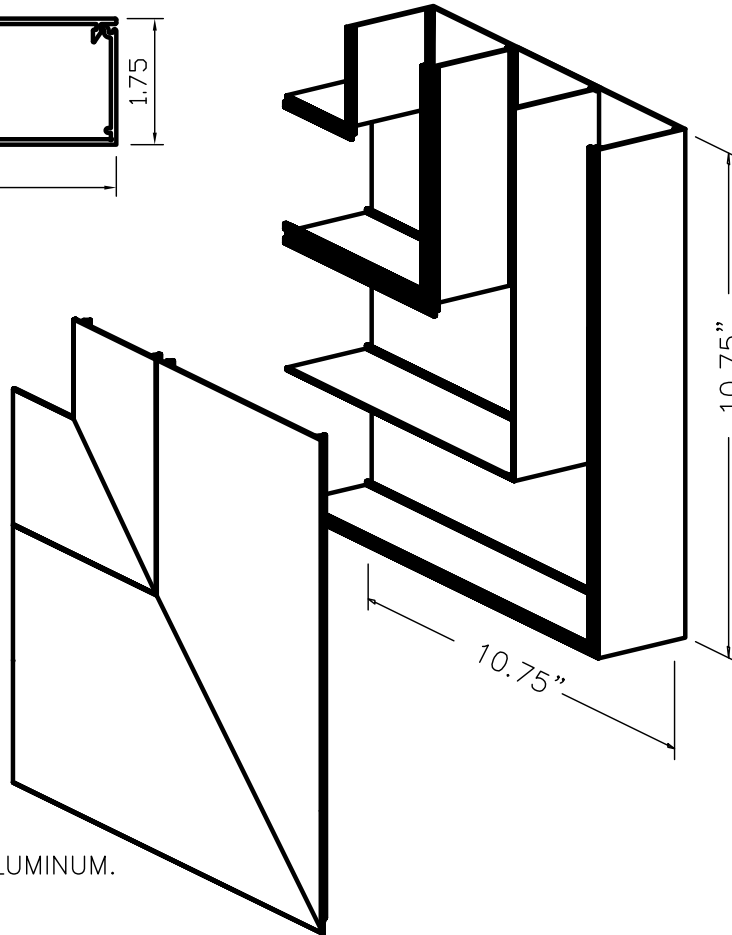

COUPLINGS
PROVIDED

MATERIAL: #6063-T6 EXTRUDED ALUMINUM.
NOMINAL WALL THICKNESS 0.075".
FINISH: SATIN ANODIZED



 MONO-SYSTEMS, INC. UNIQUE CABLE DISTRIBUTION SOLUTIONS		DRAWING TITLE: SWA7200 SERIES RACEWAY FLAT 90 DEGREE ELBOW		DR. BY: JFM	
				APP'VD BY:	
PART NUMBER CS-SWA7209	BUFFALO OFFICE: 180 HOPKINS STREET BUFFALO, NEW YORK 14220 PHONE: (716)-821-1344 FAX: (716)-821-1345	CORPORATE OFFICE: 4 INTERNATIONAL DRIVE RYE BROOK, NEW YORK 10573 PHONE: (914) 934-2075 FAX: (914) 934-2190	PROJECT: ALUMINUM SURFACE RACEWAY	SCALE: NTS	DWG. NO. CS-SWA7209 REVO
				DATE: 12/30/2010	

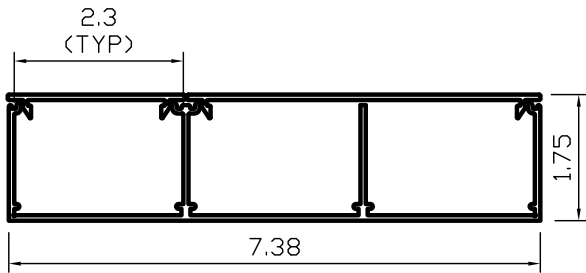

SWA7200 SERIES
ALUMINUM RACEWAY
SECTION VIEW
SATIN ANNOXIDIZED FINISH
(EACH ORDERED SEPARATELY)

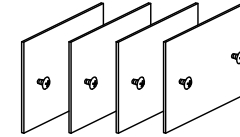
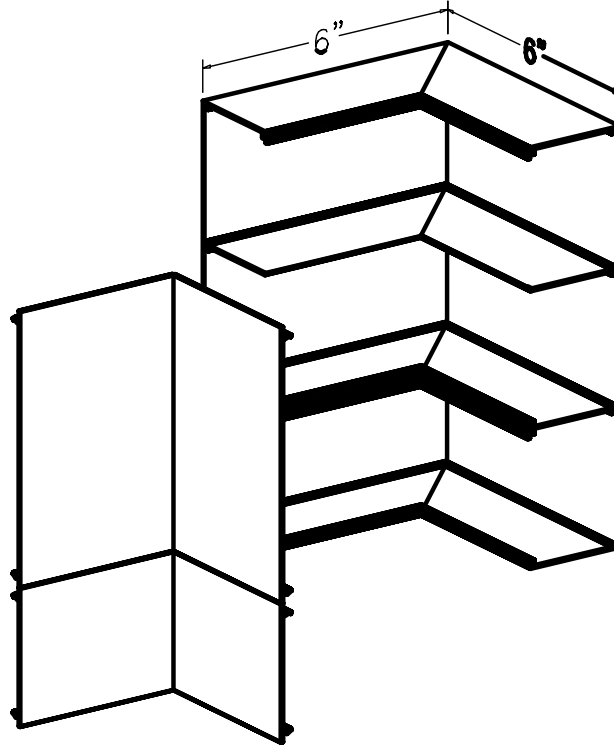

COUPLINGS
PROVIDED

MATERIAL: #6063-T6 EXTRUDED ALUMINUM.
NOMINAL WALL THICKNESS 0.075".
FINISH: SATIN ANODIZED



MONO-SYSTEMS, INC. UNIQUE CABLE DISTRIBUTION SOLUTIONS		DRAWING TITLE: SWA7200 SERIES RACEWAY INTERNAL 90 DEGREE ELBOW		DR. BY: JFM		
				APPV'D BY:		
PART NUMBER CS-SWA7214		BUFFALO OFFICE: 180 HOPKINS STREET BUFFALO, NEW YORK 14220 PHONE: (716)-821-1344 FAX: (716)-821-1345	CORPORATE OFFICE: 4 INTERNATIONAL DRIVE RYE BROOK, NEW YORK 10573 PHONE: (914) 934-2075 FAX: (914) 934-2190	PROJECT: ALUMINUM SURFACE RACEWAY	SCALE: NTS DATE: 12/30/2010	DWG. NO. CS-SWA7214 REVO

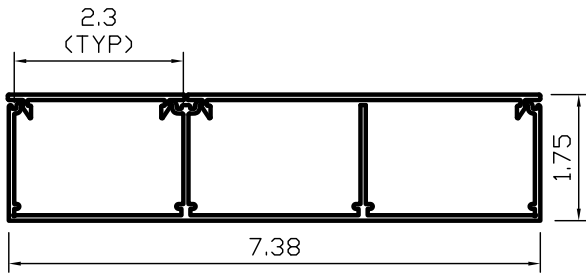

SWA7200 SERIES
ALUMINUM RACEWAY
SECTION VIEW
SATIN ANNOIDIZED FINISH
(EACH ORDERED SEPARATELY)

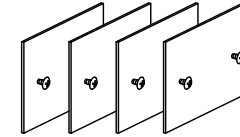
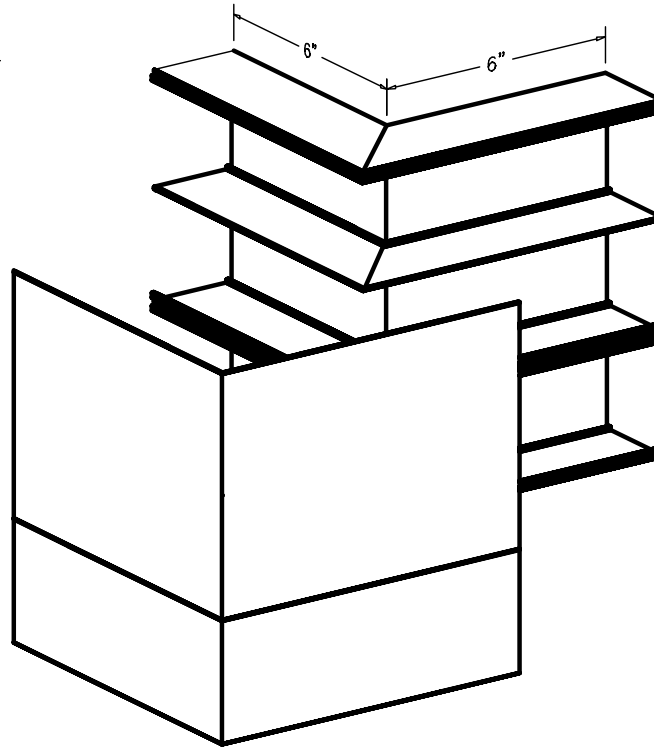

COUPLINGS
PROVIDED

MATERIAL: #6063-T6 EXTRUDED ALUMINUM.
NOMINAL WALL THICKNESS 0.075".
FINISH: SATIN ANODIZED



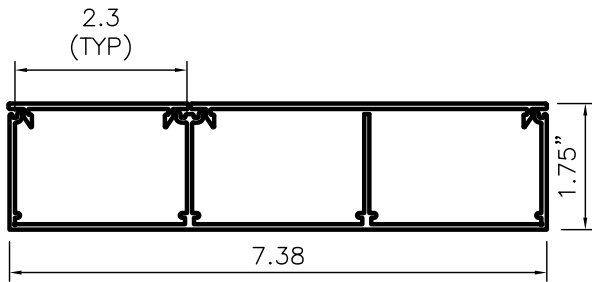

 MONO-SYSTEMS, INC. UNIQUE CABLE DISTRIBUTION SOLUTIONS	<i>DRAWING TITLE:</i>		<i>DR. BY:</i>		
	SWA7200 SERIES RACEWAY EXTERNAL 90 DEGREE ELBOW		JFM		
<i>PROJECT:</i>		<i>SCALE:</i>		<i>APPV'D BY:</i>	
ALUMINUM SURFACE RACEWAY		NTS		CS-SWA7218	
<i>DATE:</i>		12/30/2010		REVO	
<i>PART NUMBER</i>		<i>BUFFALO OFFICE:</i>		<i>CORPORATE OFFICE:</i>	
CS-SWA7218		180 HOPKINS STREET BUFFALO, NEW YORK 14220 PHONE: (716)-821-1344 FAX: (716)-821-1345		4 INTERNATIONAL DRIVE RYE BROOK, NEW YORK 10573 PHONE: (914) 934-2075 FAX: (914) 934-2190	

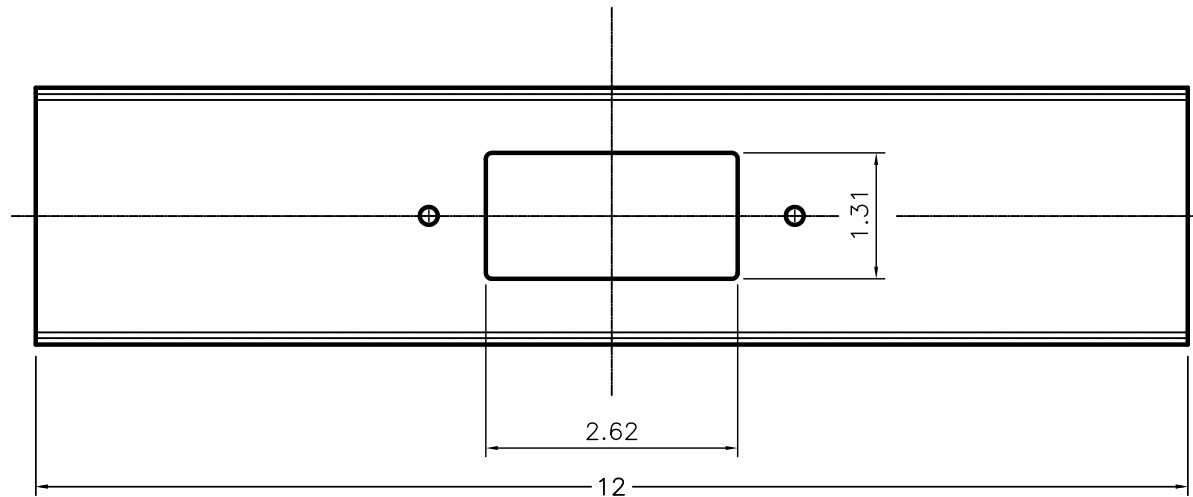

SWA7200 SERIES
ALUMINUM RACEWAY
SECTION VIEW
SATIN ANODIZED FINISH
(EACH ORDERED SEPARATELY)

MATERIAL: #6063-T6 EXTRUDED ALUMINUM.
NOMINAL WALL THICKNESS 0.075".
FINISH: SATIN ANODIZED



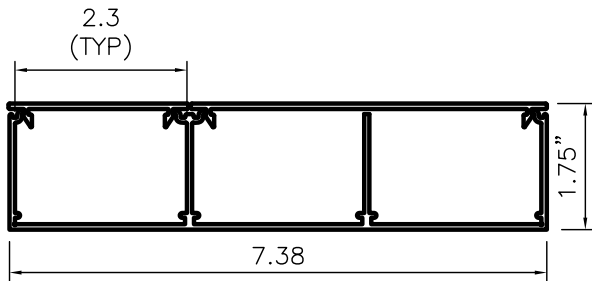

 MONO-SYSTEMS, INC. UNIQUE CABLE DISTRIBUTION SOLUTIONS	DRAWING TITLE: SWA7200 SERIES RACEWAY SINGLE COMPARTMENT DATA COVER		DR. BY: JFM		
			APPV'D BY:		
PART NUMBER CS-SWA7223-1	BUFFALO OFFICE: 180 HOPKINS STREET BUFFALO, NEW YORK 14220 PHONE: (716)-821-1344 FAX: (716)-821-1345	CORPORATE OFFICE: 4 INTERNATIONAL DRIVE RYE BROOK, NEW YORK 10573 PHONE: (914) 934-2075 FAX: (914) 934-2190	PROJECT: ALUMINUM SURFACE RACEWAY DATA CONFIGURAITON	SCALE: NTS	DWG. NO. CS-SWA7223-1 REVO
				DATE: 12/30/2010	

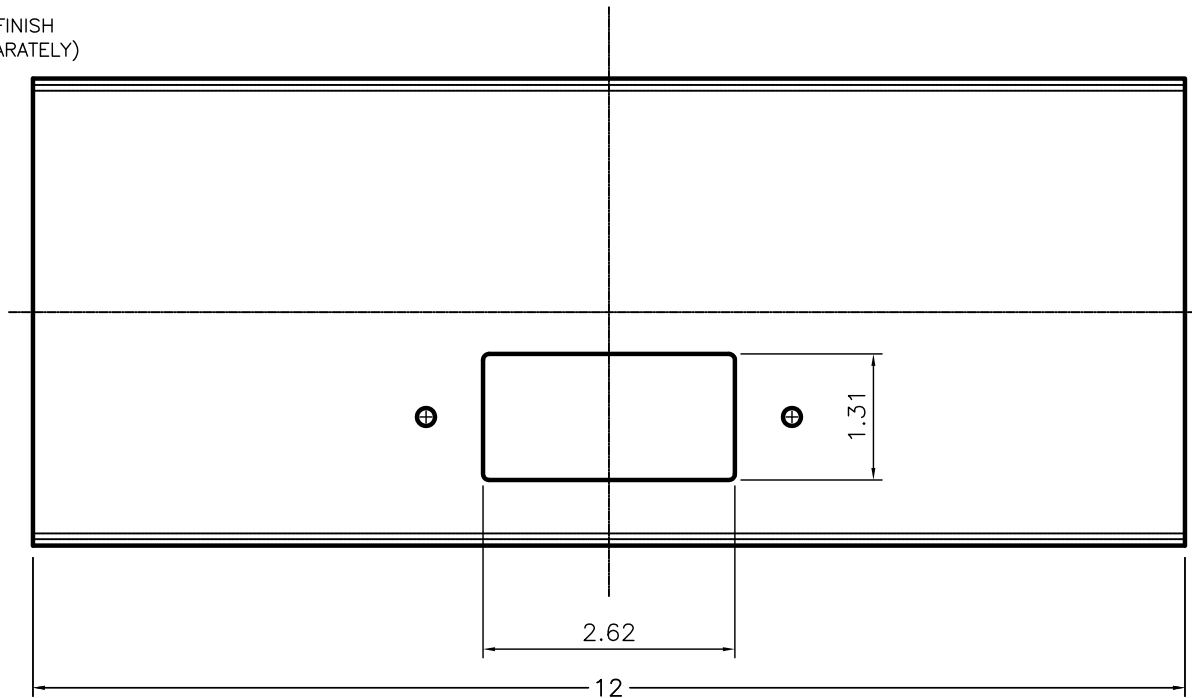

SWA7200 SERIES
ALUMINUM RACEWAY
SECTION VIEW
SATIN ANODIZED FINISH
(EACH ORDERED SEPARATELY)

MATERIAL: #6063-T6 EXTRUDED ALUMINUM.
NOMINAL WALL THICKNESS 0.075".
FINISH: SATIN ANODIZED



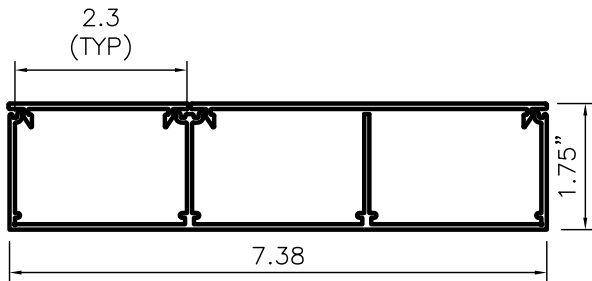

 MONO-SYSTEMS, INC. UNIQUE CABLE DISTRIBUTION SOLUTIONS	DRAWING TITLE: SWA7200 SERIES RACEWAY TWO COMPARTMENT DATA AND BLANK COVER		DR. BY: JFM		
	PROJECT: ALUMINUM SURFACE RACEWAY DATA / BLANK CONFIGURAITON		APPV'D BY:		
PART NUMBER CS-SWA7223-2	BUFFALO OFFICE: 180 HOPKINS STREET BUFFALO, NEW YORK 14220 PHONE: (716)-821-1344 FAX: (716)-821-1345	CORPORATE OFFICE: 4 INTERNATIONAL DRIVE RYE BROOK, NEW YORK 10573 PHONE: (914) 934-2075 FAX: (914) 934-2190	SCALE: NTS	DWG. NO. CS-SWA7223-2 REVO	
			DATE: 12/30/2010		

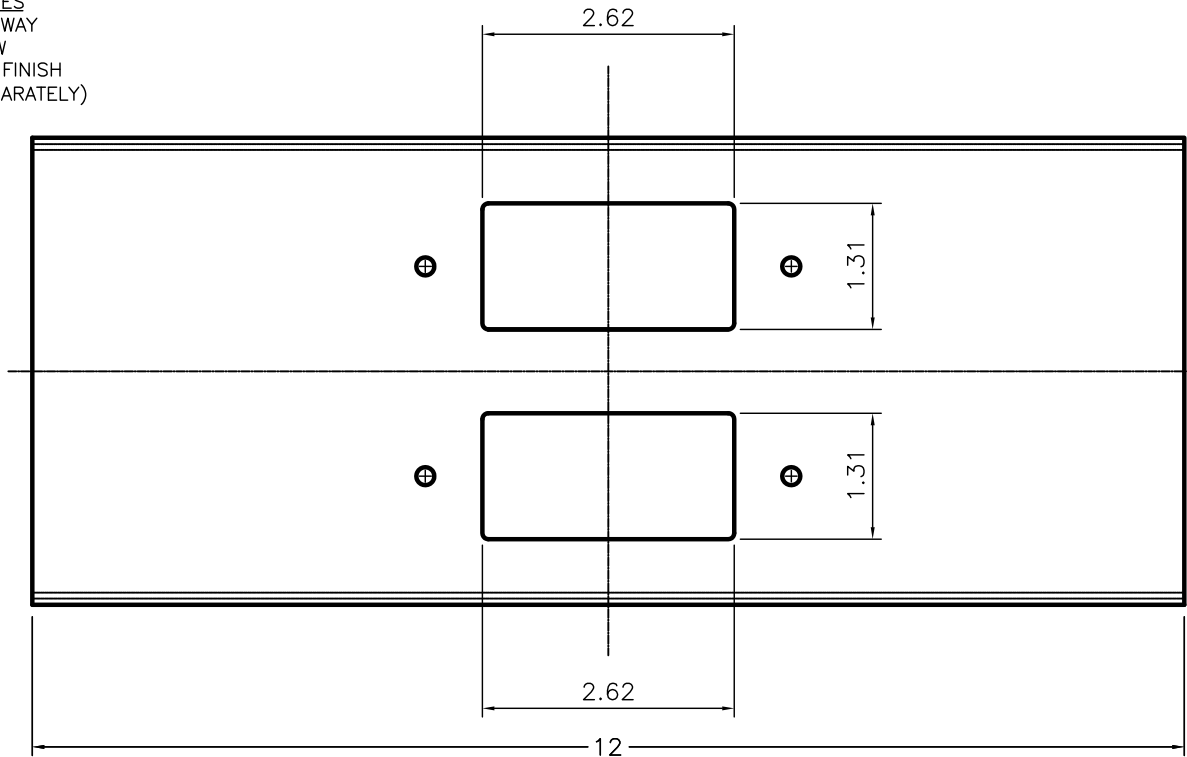

SWA7200 SERIES
ALUMINUM RACEWAY
SECTION VIEW
SATIN ANODIZED FINISH
(EACH ORDERED SEPARATELY)

MATERIAL: #6063-T6 EXTRUDED ALUMINUM.
NOMINAL WALL THICKNESS 0.075".
FINISH: SATIN ANODIZED



 MONO-SYSTEMS, INC. UNIQUE CABLE DISTRIBUTION SOLUTIONS	DRAWING TITLE: SWA7200 SERIES RACEWAY TWO COMPARTMENT DATA AND DATA COVER		DR. BY: JFM		
	PROJECT: ALUMINUM SURFACE RACEWAY DATA / DATA CONFIGURAITON		APPV'D BY:		
PART NUMBER CS-SWA7223DD-2	BUFFALO OFFICE: 180 HOPKINS STREET BUFFALO, NEW YORK 14220 PHONE: (716)-821-1344 FAX: (716)-821-1345	CORPORATE OFFICE: 4 INTERNATIONAL DRIVE RYE BROOK, NEW YORK 10573 PHONE: (914) 934-2075 FAX: (914) 934-2190	SCALE: NTS	DWG. NO. CS-SWA7223DD-2 REVO	
			DATE: 12/30/2010		

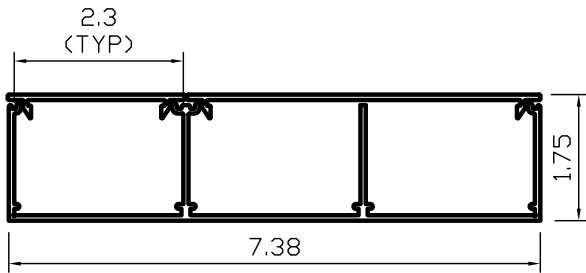

SWA7200 SERIES
ALUMINUM RACEWAY
SECTION VIEW
SATIN ANNOIDIZED FINISH
(EACH ORDERED SEPARATELY)

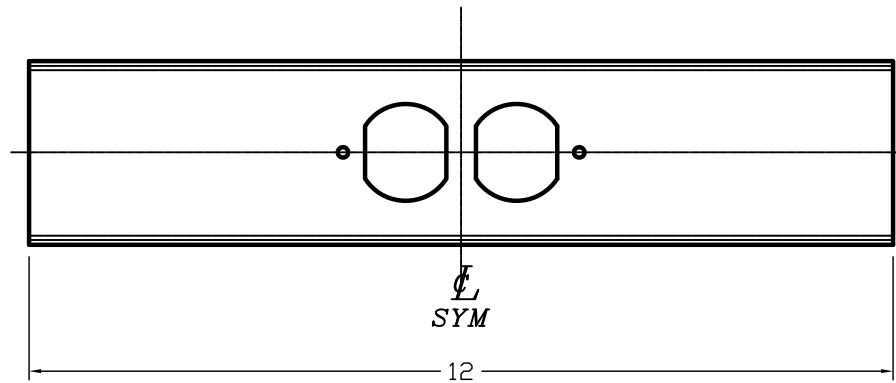

MATERIAL: #6063-T6 EXTRUDED ALUMINUM.
NOMINAL WALL THICKNESS 0.075".
FINISH: SATIN ANODIZED



 MONO-SYSTEMS, INC. UNIQUE CABLE DISTRIBUTION SOLUTIONS	DRAWING TITLE: SWA7200 SERIES RACEWAY SINGLE COMPARTMENT DUPLEX COVER		DR. BY: JFM		
			APP'VD BY:		
PART NUMBER CS-SWA7246-1	BUFFALO OFFICE: 180 HOPKINS STREET BUFFALO, NEW YORK 14220 PHONE: (716)-821-1344 FAX: (716)-821-1345	CORPORATE OFFICE: 4 INTERNATIONAL DRIVE RYE BROOK, NEW YORK 10573 PHONE: (914) 934-2075 FAX: (914) 934-2190	PROJECT: ALUMINUM SURFACE RACEWAY	SCALE: NTS DATE: 12/30/2010	DWG. NO. CS-SWA7246-1 REVO

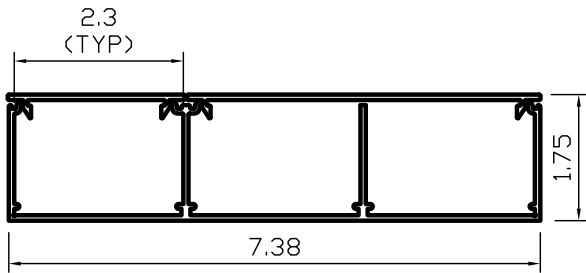

SWA7200 SERIES
ALUMINUM RACEWAY
SECTION VIEW
SATIN ANNOIDIZED FINISH
(EACH ORDERED SEPARATELY)

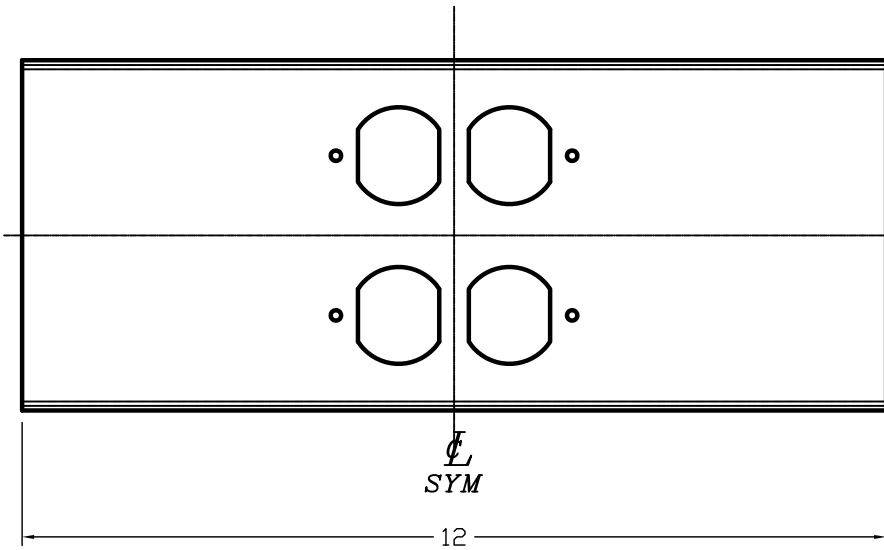

MATERIAL: #6063-T6 EXTRUDED ALUMINUM.
NOMINAL WALL THICKNESS 0.075".
FINISH: SATIN ANODIZED



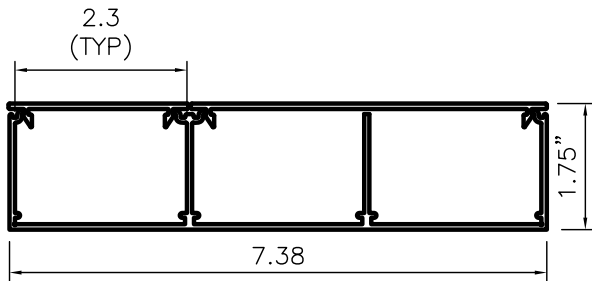

PART NUMBER CS-SWA7246DD-2	 MONO-SYSTEMS, INC. UNIQUE CABLE DISTRIBUTION SOLUTIONS	BUFFALO OFFICE: 180 HOPKINS STREET BUFFALO, NEW YORK 14220 PHONE: (716)-821-1344 FAX: (716)-821-1345	CORPORATE OFFICE: 4 INTERNATIONAL DRIVE RYE BROOK, NEW YORK 10573 PHONE: (914) 934-2075 FAX: (914) 934-2190	<i>DRAWING TITLE:</i>	DR. BY:
				SWA7200 SERIES RACEWAY TWO COMPARTMENT 2-DUPLEX COVER	JFM
				<i>PROJECT:</i>	SCALE:
				ALUMINUM SURFACE RACEWAY	NTS
					DATE:
					12/30/2010
					DWG. NO.
					CS-SWA7246DD-2
					REVO

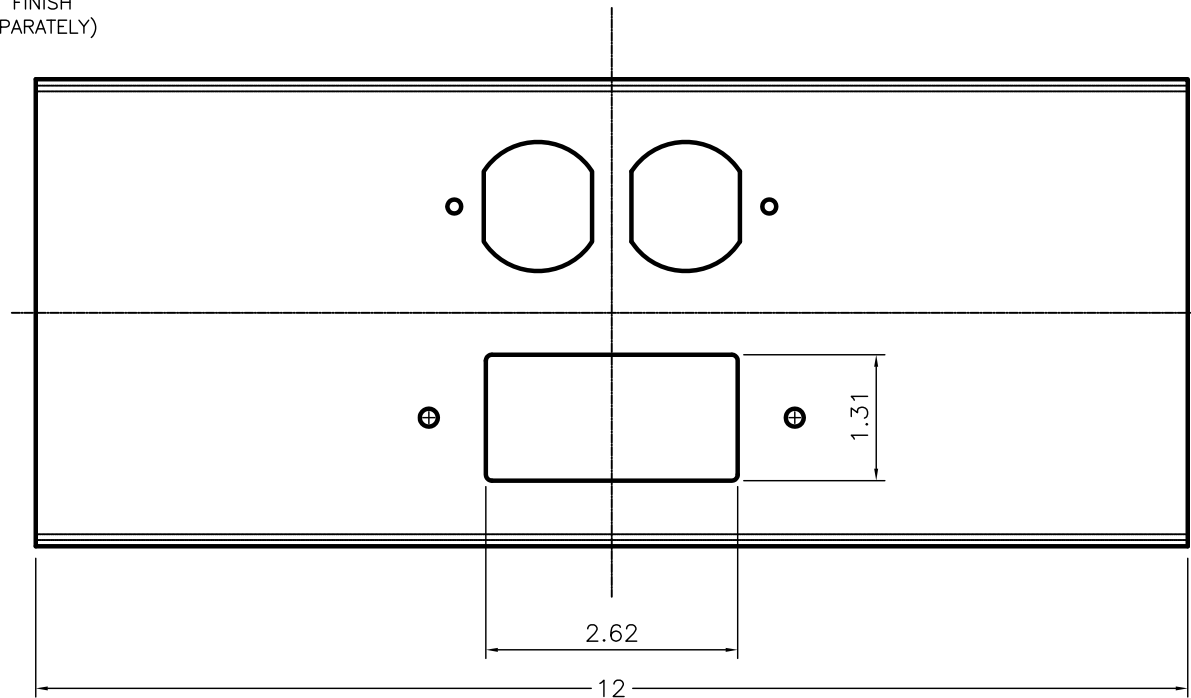

SWA7200 SERIES
ALUMINUM RACEWAY
SECTION VIEW
SATIN ANODIZED FINISH
(EACH ORDERED SEPARATELY)

MATERIAL: #6063-T6 EXTRUDED ALUMINUM.
NOMINAL WALL THICKNESS 0.075".
FINISH: SATIN ANODIZED



 MONO-SYSTEMS, INC. UNIQUE CABLE DISTRIBUTION SOLUTIONS	<i>DRAWING TITLE:</i>		<i>DR. BY:</i>		
	SWA7200 SERIES RACEWAY TWO COMPARTMENT DEVICE COVER		JFM		
<i>PROJECT:</i>		<i>SCALE:</i>		<i>APPV'D BY:</i>	
ALUMINUM SURFACE RACEWAY DUPLEX / DECOR CONFIGURAITON		NTS		REVO	
<i>DATE:</i>		12/30/2010		<i>DWG. NO.</i>	
CS-SWA7248DD-2		180 HOPKINS STREET BUFFALO, NEW YORK 14220 PHONE: (716)-821-1344 FAX: (716)-821-1345		4 INTERNATIONAL DRIVE RYE BROOK, NEW YORK 10573 PHONE: (914) 934-2075 FAX: (914) 934-2190	

PART NUMBER
CS-SWA7248DD-2

BUFFALO OFFICE:
180 HOPKINS STREET
BUFFALO, NEW YORK 14220
PHONE: (716)-821-1344
FAX: (716)-821-1345

CORPORATE OFFICE:
4 INTERNATIONAL DRIVE
RYE BROOK, NEW YORK 10573
PHONE: (914) 934-2075
FAX: (914) 934-2190

PROJECT:
ALUMINUM SURFACE RACEWAY
DUPLEX / DECOR CONFIGURAITON

SCALE:
NTS
DATE:
12/30/2010

DR. BY:
JFM
APPV'D BY:
DWG. NO.
CS-SWA7248DD-2
REVO

SWA7200 SERIES
 SWA7257 - UNIVERSAL DEVICE PLATE

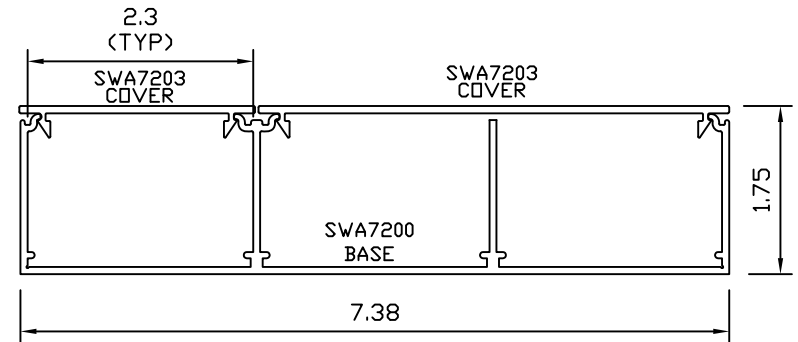
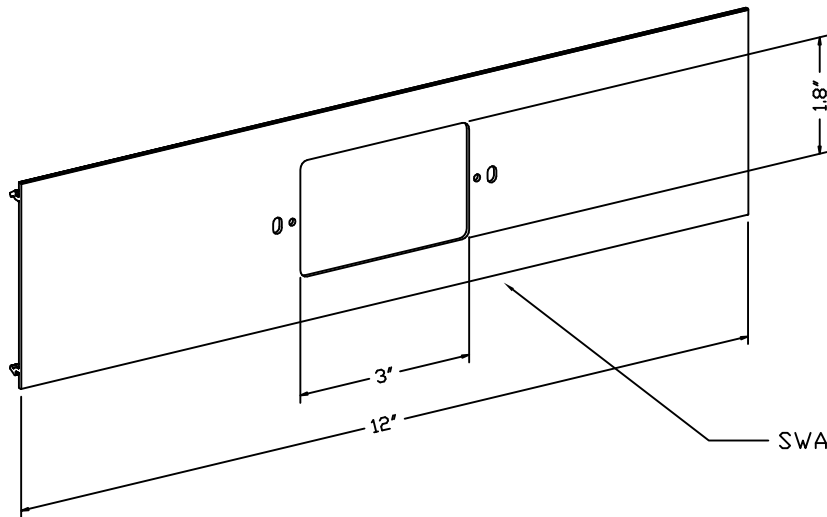

SWA7200 SERIES
 ALUMINUM RACEWAY
 SECTION VIEW
 SATIN ANNOXIDIZED FINISH
 (EACH ORDERED SEPARATELY)

SWA7257 - UNIVERSAL DEVICE PLATE



MONO-SYSTEMS, INC.
 UNIQUE CABLE DISTRIBUTION SOLUTIONS
 4 INTERNATIONAL DRIVE
 RYE BROOK, NEW YORK 10573
 PHONE: (914)-934-2075
 FAX: (914)-934-2190

SWA7200 SERIES
 SWA7225-1 - 1.4" ROUND OPENING SINGLE COMP. DEVICE PLATE

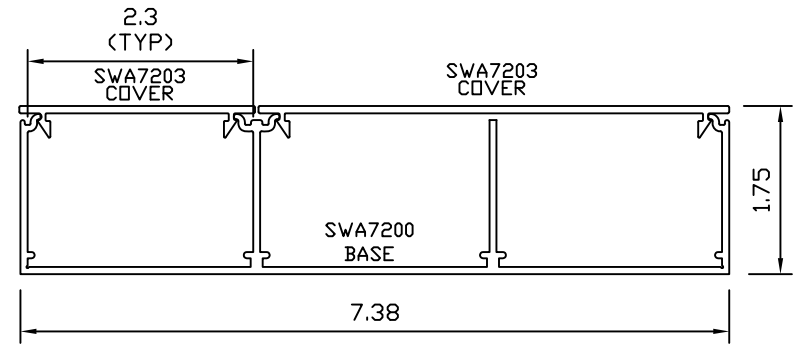
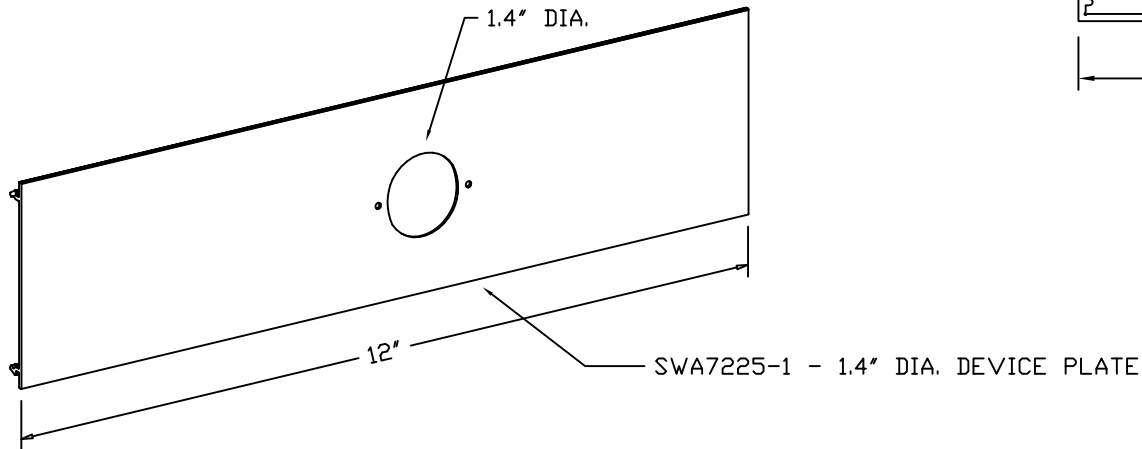

SWA7200 SERIES
 ALUMINUM RACEWAY
 SECTION VIEW
 SATIN ANNOXIDIZED FINISH
 (EACH ORDERED SEPARATELY)



MONO-SYSTEMS, INC.
 UNIQUE CABLE DISTRIBUTION SOLUTIONS
 4 INTERNATIONAL DRIVE
 RYE BROOK, NEW YORK 10573
 PHONE: (914)-934-2075
 FAX: (914)-934-2190

SWA7200 SERIES
 SWA7225-2 - 1.4" ROUND OPENING/BLANK TWO COMP. DEVICE PLATE

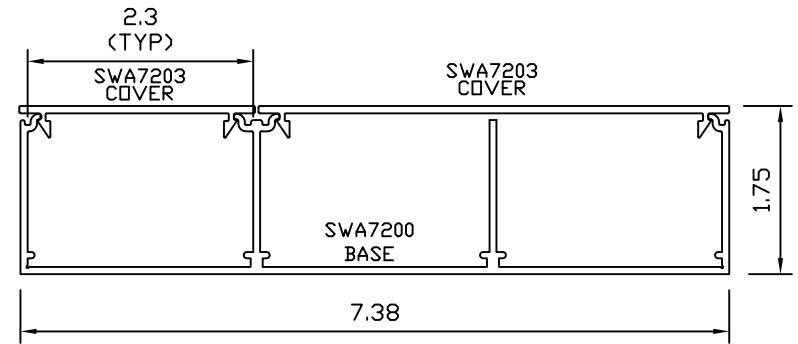
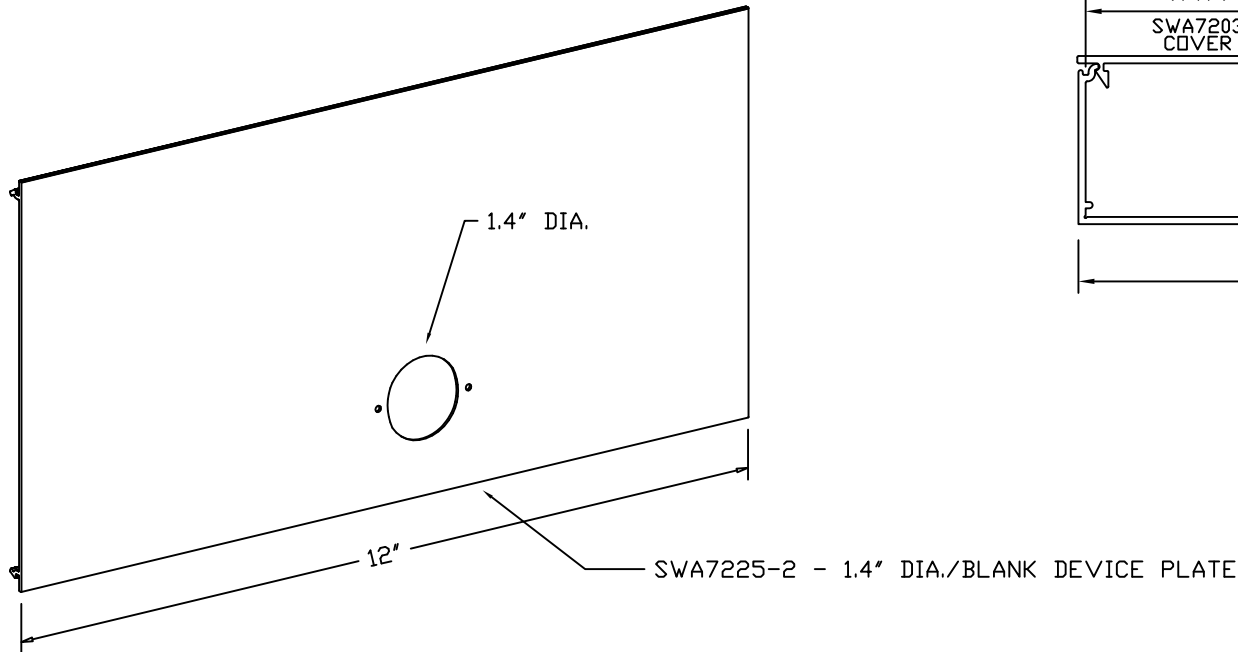

SWA7200 SERIES
 ALUMINUM RACEWAY
 SECTION VIEW
 SATIN ANNOXIDIZED FINISH
 (EACH ORDERED SEPARATELY)



MONO-SYSTEMS, INC.
 UNIQUE CABLE DISTRIBUTION SOLUTIONS
 4 INTERNATIONAL DRIVE
 RYE BROOK, NEW YORK 10573
 PHONE: (914)-934-2075
 FAX: (914)-934-2190

SWA7200 SERIES
 SWA7226-1 - 1.59" ROUND OPENING SINGLE COMP. DEVICE PLATE

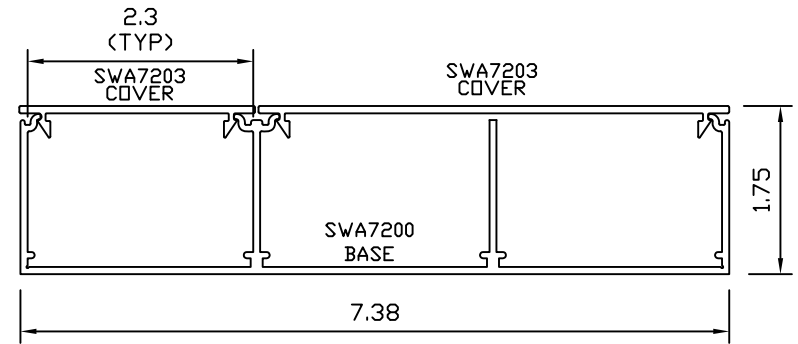
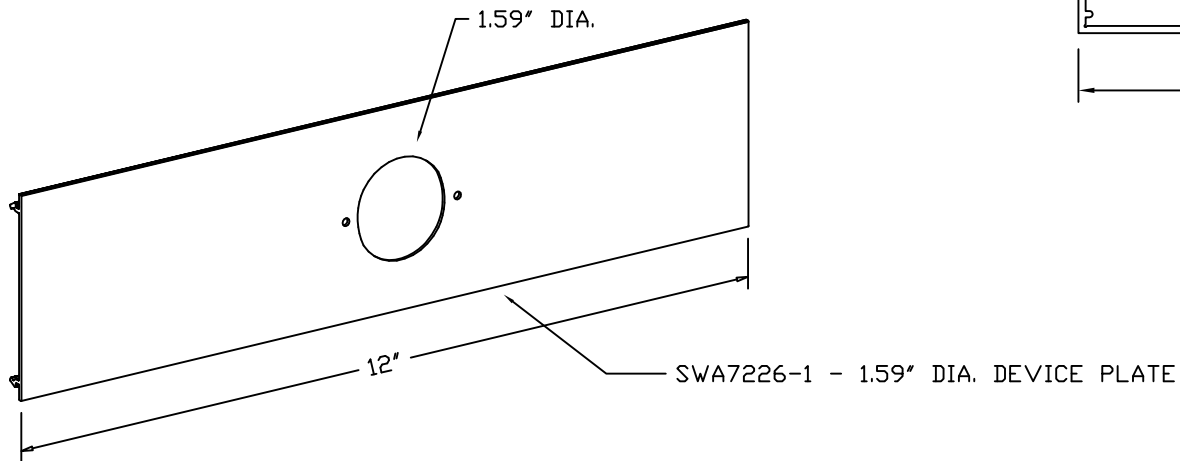

SWA7200 SERIES
 ALUMINUM RACEWAY
 SECTION VIEW
 SATIN ANNOXIDIZED FINISH
 (EACH ORDERED SEPARATELY)



MONO-SYSTEMS, INC.
 UNIQUE CABLE DISTRIBUTION SOLUTIONS
 4 INTERNATIONAL DRIVE
 RYE BROOK, NEW YORK 10573
 PHONE: (914)-934-2075
 FAX: (914)-934-2190

SWA7200 SERIES
 SWA7226-2 - 1.59" ROUND OPENING/BLANK TWO COMP. DEVICE PLATE

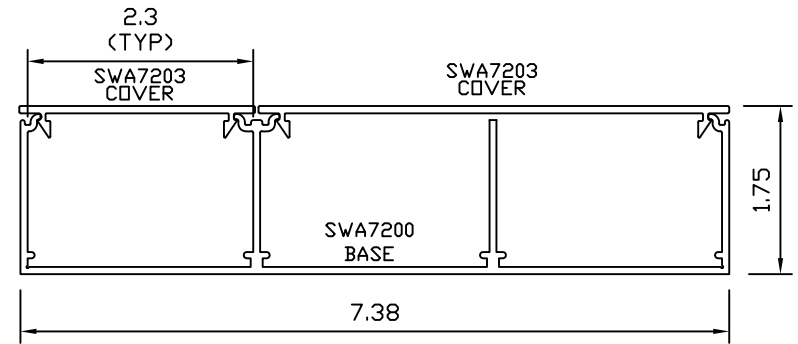
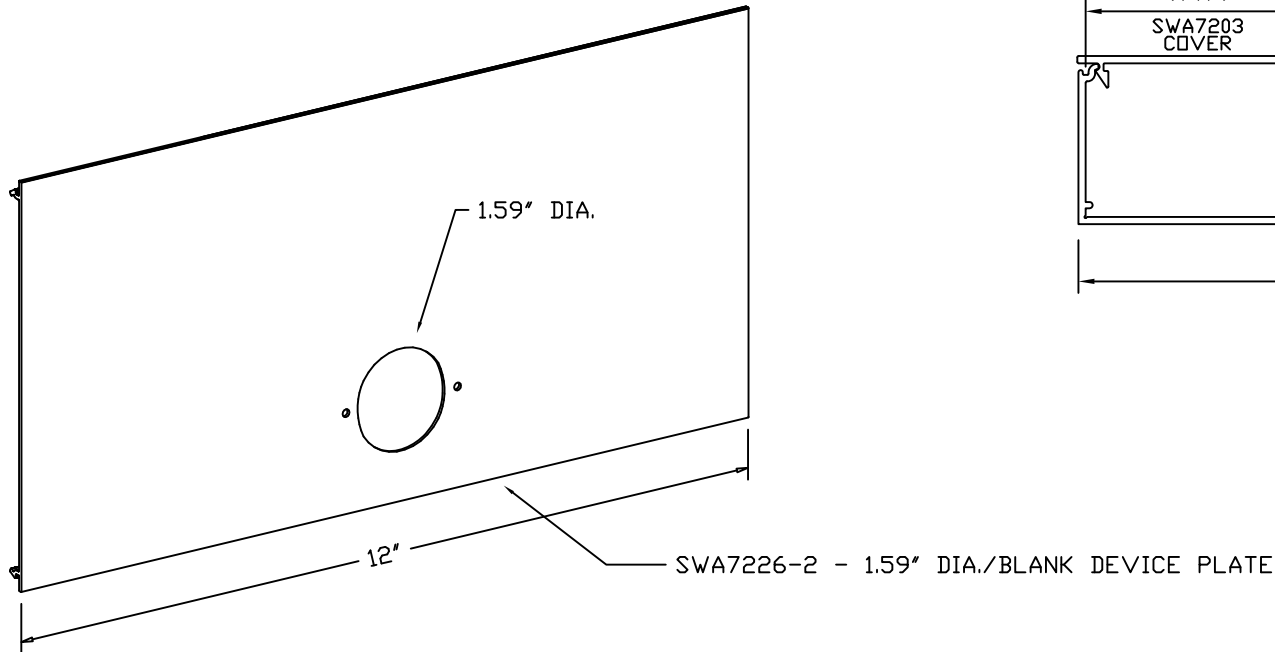

SWA7200 SERIES
 ALUMINUM RACEWAY
 SECTION VIEW
 SATIN ANNOXIDIZED FINISH
 (EACH ORDERED SEPARATELY)



MONO-SYSTEMS, INC.
 UNIQUE CABLE DISTRIBUTION SOLUTIONS
 4 INTERNATIONAL DRIVE
 RYE BROOK, NEW YORK 10573
 PHONE: (914)-934-2075
 FAX: (914)-934-2190

SWA7200 SERIES
 SWA7245-1 - 2.16" ROUND OPENING SINGLE COMP. DEVICE PLATE

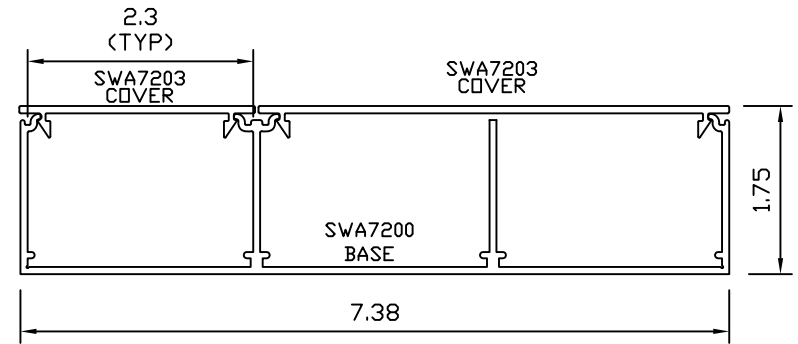
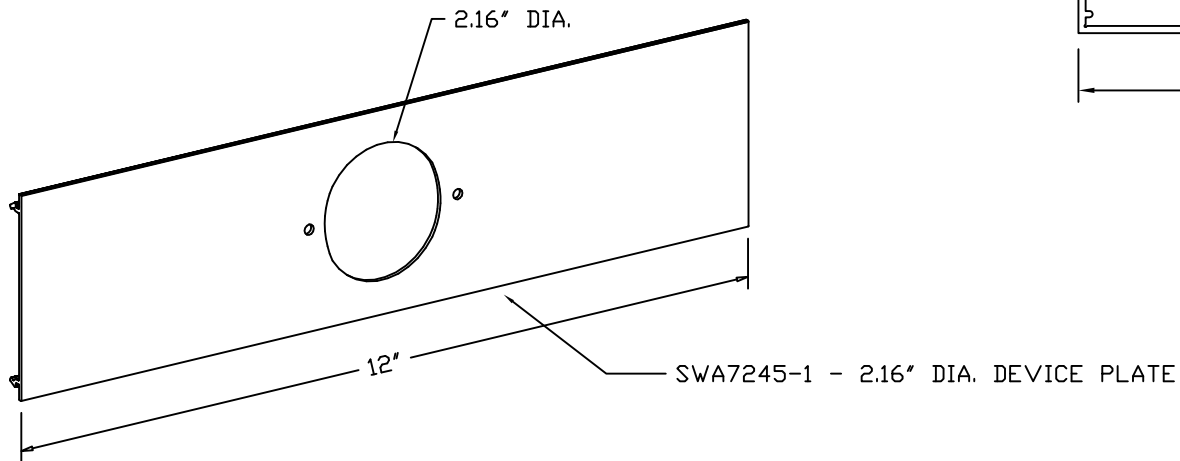

SWA7200 SERIES
 ALUMINUM RACEWAY
 SECTION VIEW
 SATIN ANNOIDIZED FINISH
 (EACH ORDERED SEPARATELY)



MONO-SYSTEMS, INC.
 UNIQUE CABLE DISTRIBUTION SOLUTIONS
 4 INTERNATIONAL DRIVE
 RYE BROOK, NEW YORK 10573
 PHONE: (914)-934-2075
 FAX: (914)-934-2190

SWA7200 SERIES

SWA7245-2 - 2.16" ROUND OPENING/BLANK TWO COMP. DEVICE PLATE

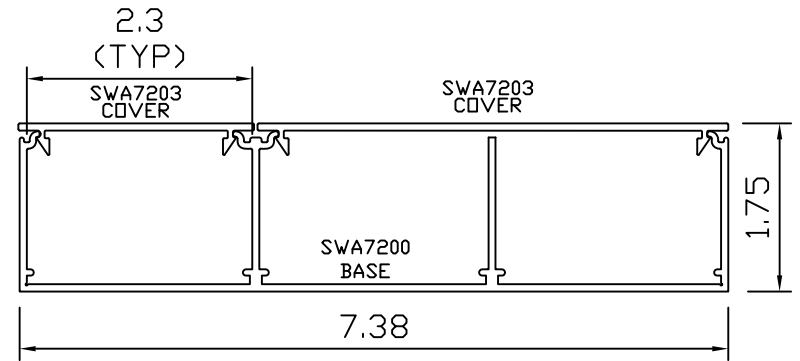
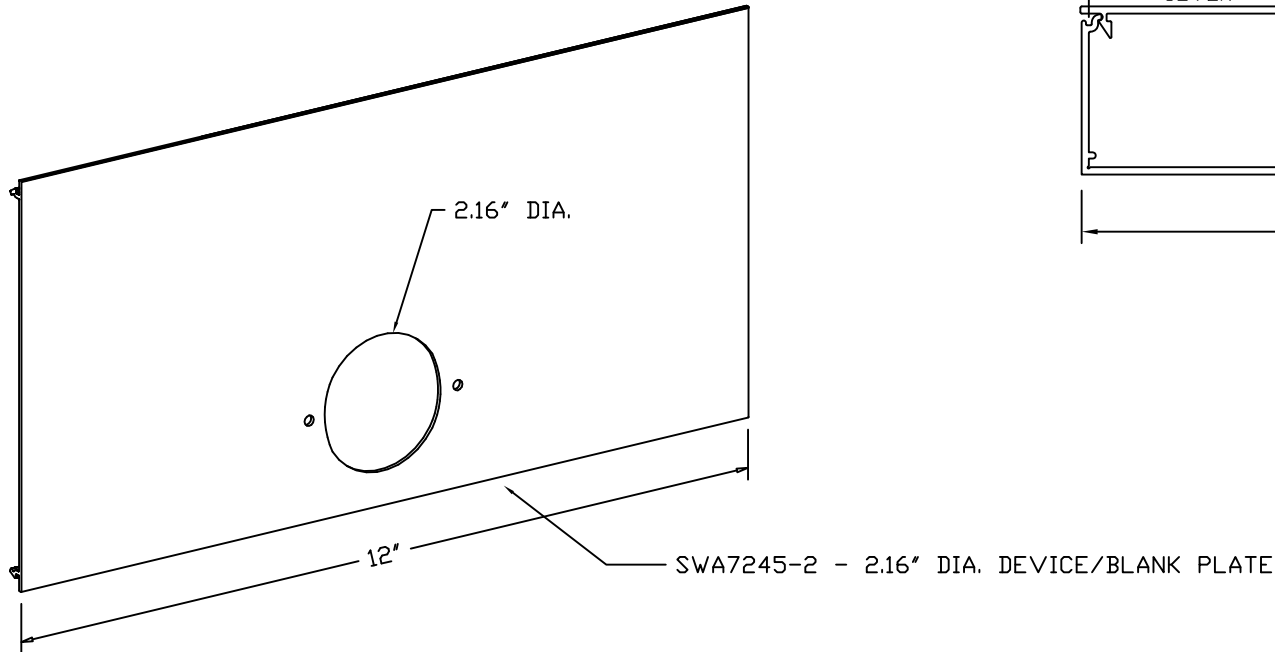

SWA7200 SERIES
ALUMINUM RACEWAY
SECTION VIEW
SATIN ANNOIDIZED FINISH
(EACH ORDERED SEPARATELY)



MONO-SYSTEMS, INC.
UNIQUE CABLE DISTRIBUTION SOLUTIONS
4 INTERNATIONAL DRIVE
RYE BROOK, NEW YORK 10573
PHONE: (914)-934-2075
FAX: (914)-934-2190