

Mono-Systems, Inc.
SnapMark (tm)
SMS4400 SERIES

BASE - 10' [3m] (SMS4400)

SCALE: NONE

AVAILABLE IN STANDARD GRAY OR IVORY
 (ADD "-I" SUFFIX TO SPECIFY IVORY)

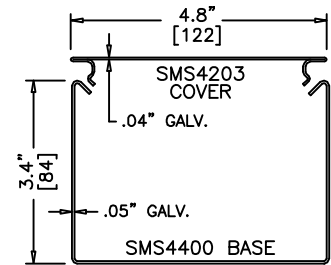

SMS4400 SERIES
 STEEL RACEWAY
 SECTION VIEW
 EACH ORDERED SEPARATELY
 SCALE: NONE

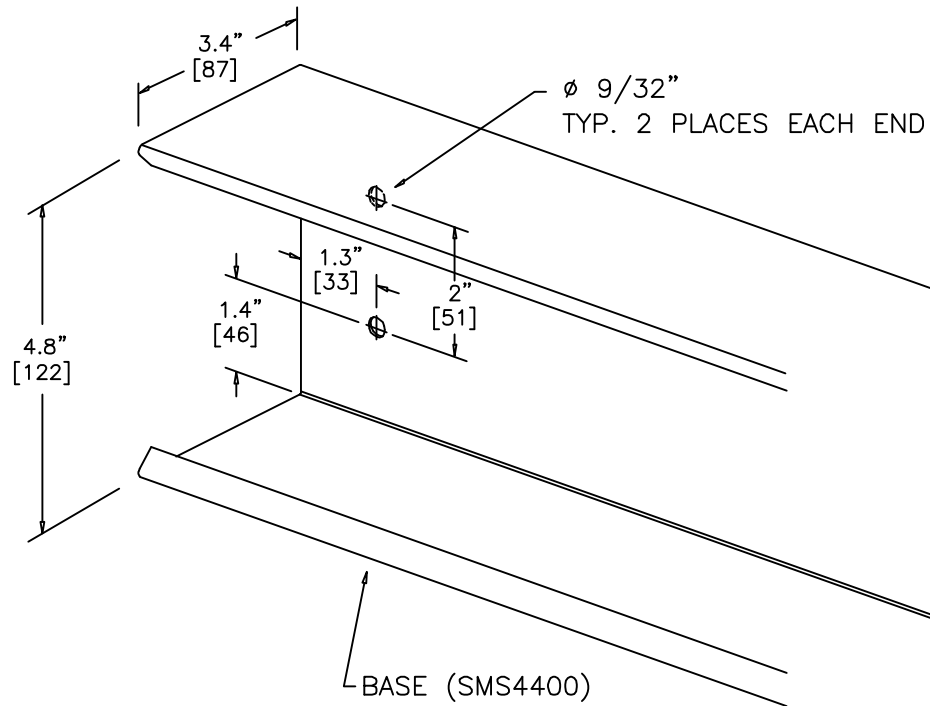

ASSEMBLY INSTRUCTIONS

1. RIGIDLY SECURE BASE SECTION TO STRUCTURAL BUILDING MEMBER OR WALL CONSTRUCTION AT 18" MAXIMUM MOUNTING CENTERS. ENGINEER TO VERIFY FASTENERS & MOUNTING INTERVAL BASED ON MOUNTING SURFACE CONSTRUCTION. (HARDWARE BY OTHERS)



MONO-SYSTEMS, INC.
 UNIQUE CABLE DISTRIBUTION SOLUTIONS
 4 INTERNATIONAL DRIVE
 RYE BROOK, NEW YORK 10573
 PHONE: (914)-934-2075
 FAX: (914)-934-2190

DIVIDER CLIP (SMS4401)

SCALE: NONE

GALVANIZED STEEL – UNPAINTED

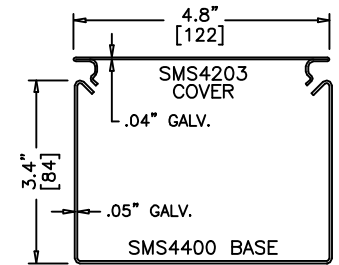

SMS4400 SERIES
STEEL RACEWAY
 SECTION VIEW
 EACH ORDERED SEPARATELY
 SCALE: NONE

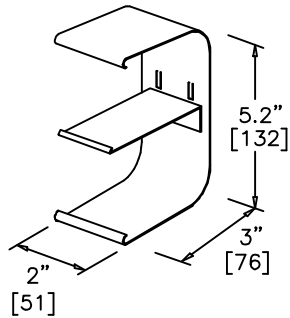

DIVIDER CLIP (SMS4401)

① RETAINER TABS
 (BEND AWAY FROM
 BACK SURFACE)

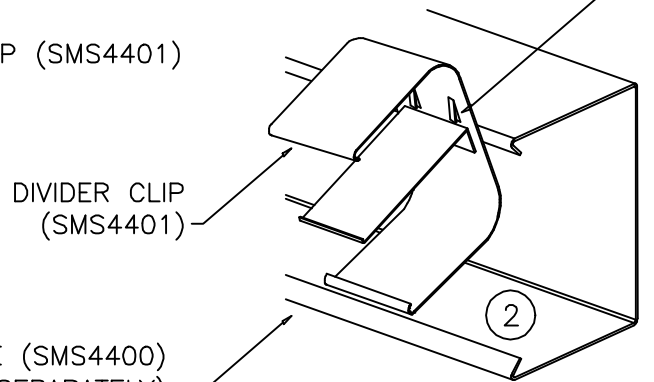

DIVIDER CLIP
 (SMS4401)

BASE (SMS4400)
 (ORDER SEPARATELY)

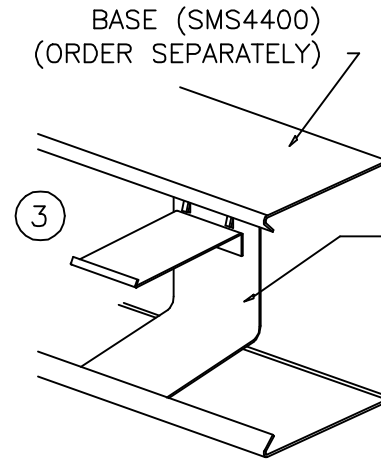

BASE (SMS4400)
 (ORDER SEPARATELY)

DIVIDER CLIP
 (SMS4401)

ASSEMBLY INSTRUCTIONS

1. BEND OUT RETAINER TABS APPROX. 1/16" AWAY FROM BACK SURFACE AS SHOWN.
2. INSERT DIVIDER CLIP INTO RACEWAY ONE LEG AT A TIME AS SHOWN.
3. FIRMLY PRESS CLIP INTO PLACE ENSURING THAT BOTH SIDES ARE COMPLETELY SNAPPED INTO LIPS OF BASE SECTION AS SHOWN.
4. POSITION SMS4407 DIVIDER STRIP INTO PLACE. SNAP INTO RETAINER TABS AS SHOWN TO SECURE DIVIDER STRIP IN PLACE. (PUSH RETAINER TABS BACK IN TO REMOVE DIVIDER STRIP IF REQUIRED).

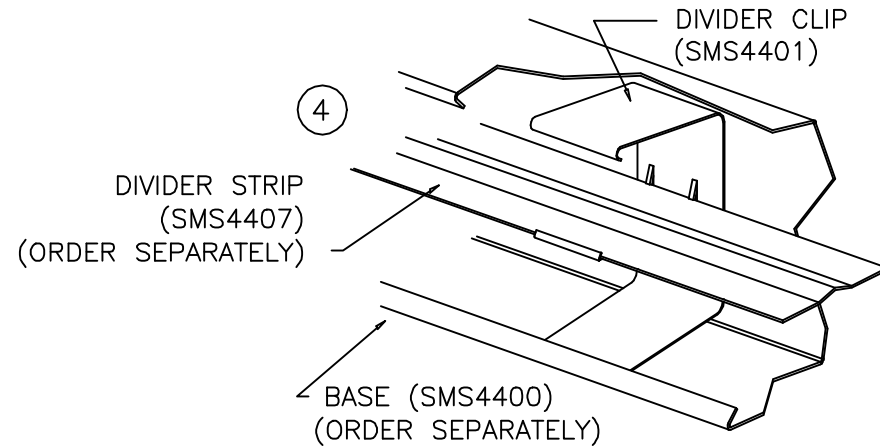

DIVIDER STRIP
 (SMS4407)
 (ORDER SEPARATELY)

BASE (SMS4400)
 (ORDER SEPARATELY)



Mono-Systems, Inc.
SnapMark (tm)
SMS4400 SERIES

COUPLING (SMS4402)

SCALE: NONE

GALVANIZED STEEL - UNPAINTED

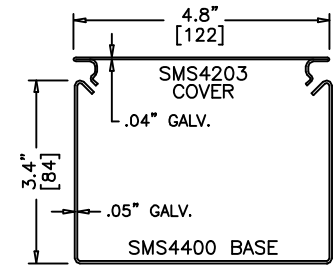

SMS4400 SERIES
STEEL RACEWAY
SECTION VIEW
 EACH ORDERED SEPARATELY
 SCALE: NONE

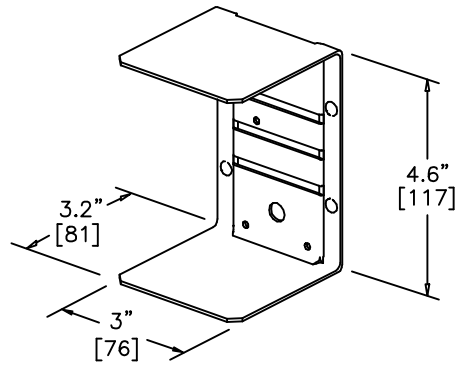

COUPLING (SMS4402)

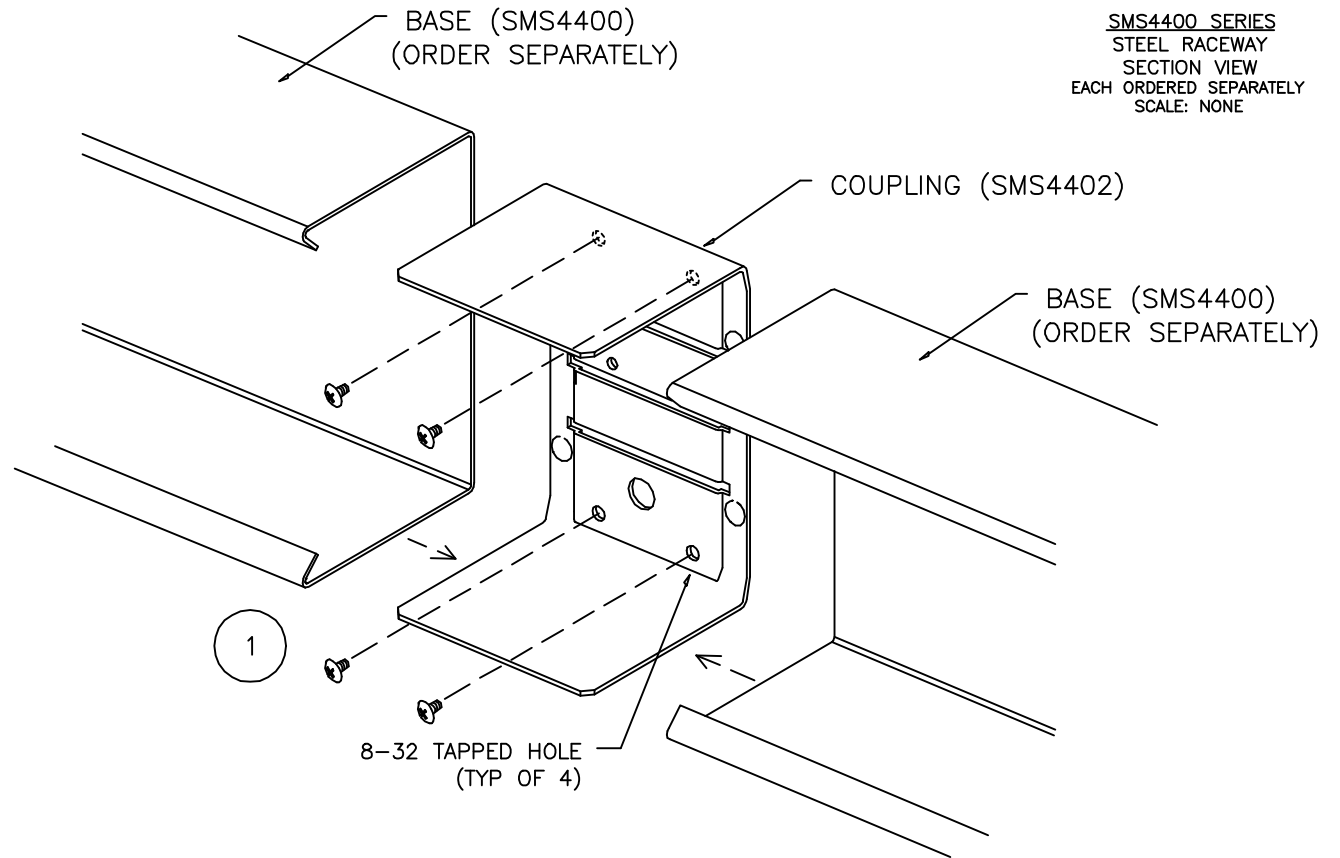

ASSEMBLY INSTRUCTIONS

1. INSERT COUPLING INTO ENDS OF SMS4400 BASE SECTIONS TO BE JOINED. SECURE IN PLACE USING FOUR 8-32 X 3/16" PAN HEAD SCREWS (FURNISHED).

FILENAME: 4402A.DWG



MONO-SYSTEMS, INC.
UNIQUE CABLE DISTRIBUTION SOLUTIONS
 4 INTERNATIONAL DRIVE
 RYE BROOK, NEW YORK 10573
 PHONE: (914)-934-2075
 FAX: (914)-934-2190

BLANK END FITTING (SMS4404)

SCALE: NONE

AVAILABLE IN STANDARD GRAY OR IVORY
 (ADD "-I" SUFFIX TO SPECIFY IVORY)

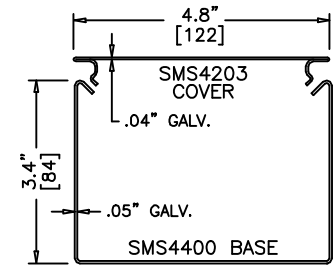

SMS4400 SERIES
STEEL RACEWAY
SECTION VIEW
 EACH ORDERED SEPARATELY
 SCALE: NONE

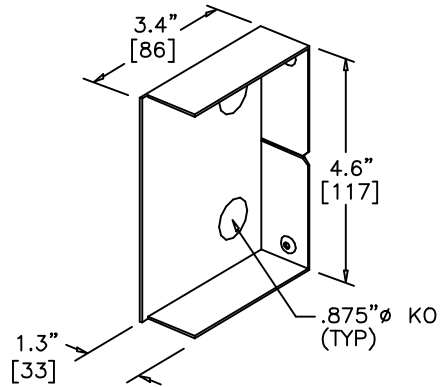

BLANK END FITTING (SMS4404)

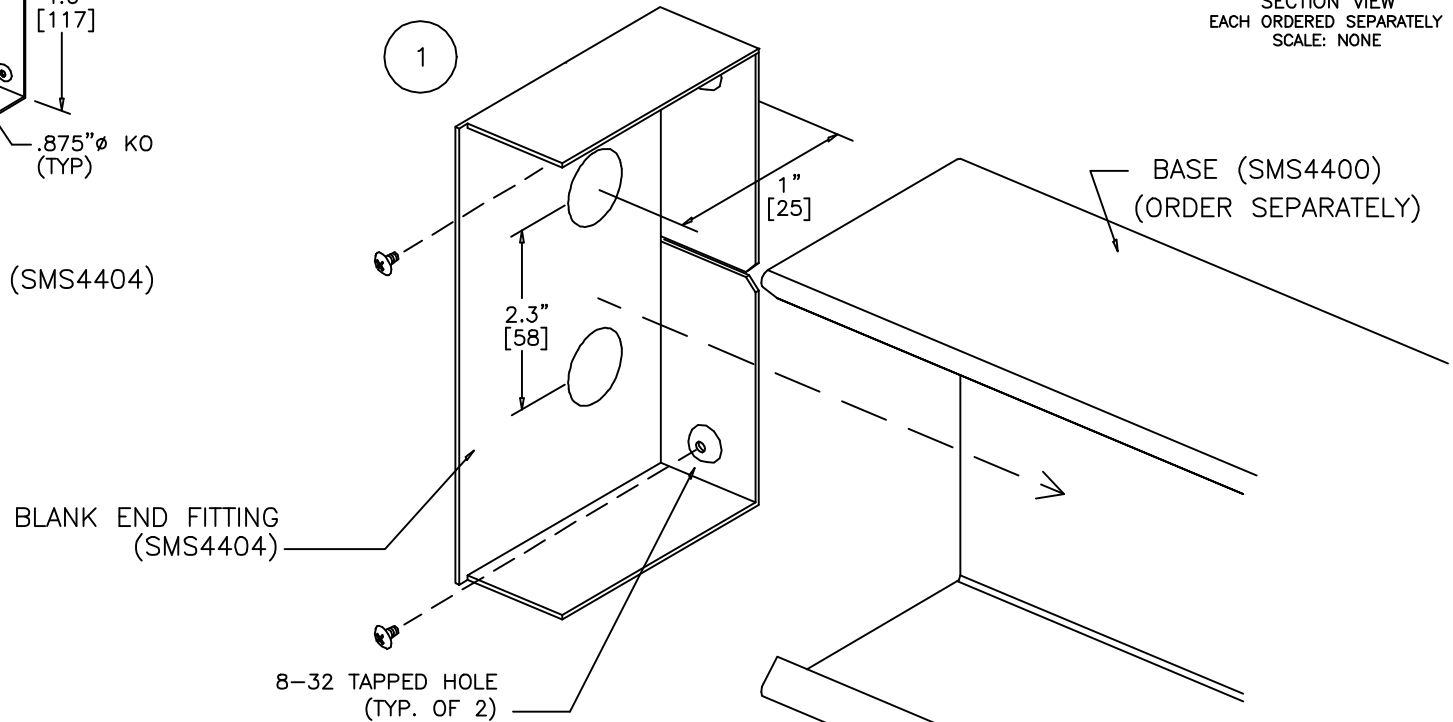

BLANK END FITTING
 (SMS4404)

8-32 TAPPED HOLE
 (TYP. OF 2)

BASE (SMS4400)
 (ORDER SEPARATELY)

ASSEMBLY INSTRUCTIONS

1. INSERT BLANK END FULLY INTO SMS4400 BASE SECTION. SECURE WITH TWO 8-32 X 3/16" PAN HEAD SCREWS (FURNISHED).



DIVIDED ENTRANCE END (SMS4405)

SCALE: NONE

AVAILABLE IN STANDARD GRAY OR IVORY
 (ADD "-I" SUFFIX TO SPECIFY IVORY)

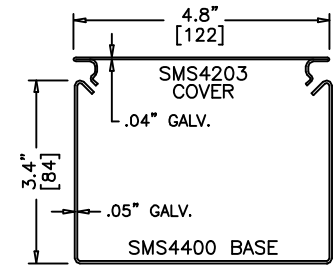

SMS4400 SERIES
STEEL RACEWAY
SECTION VIEW
 EACH ORDERED SEPARATELY
 SCALE: NONE

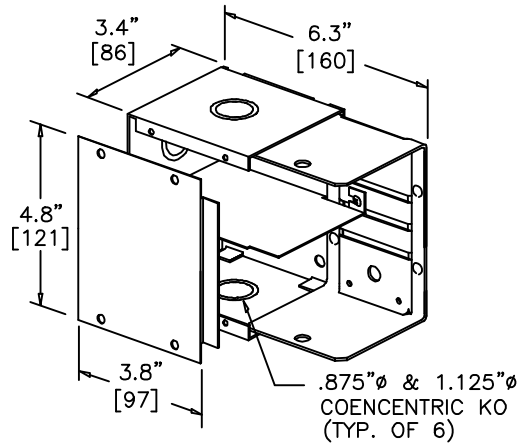

DIVIDED ENTRANCE END (SMS4405)

SMS4405 COVER
 (FURNISHED)

TYP. OF 4 (3)

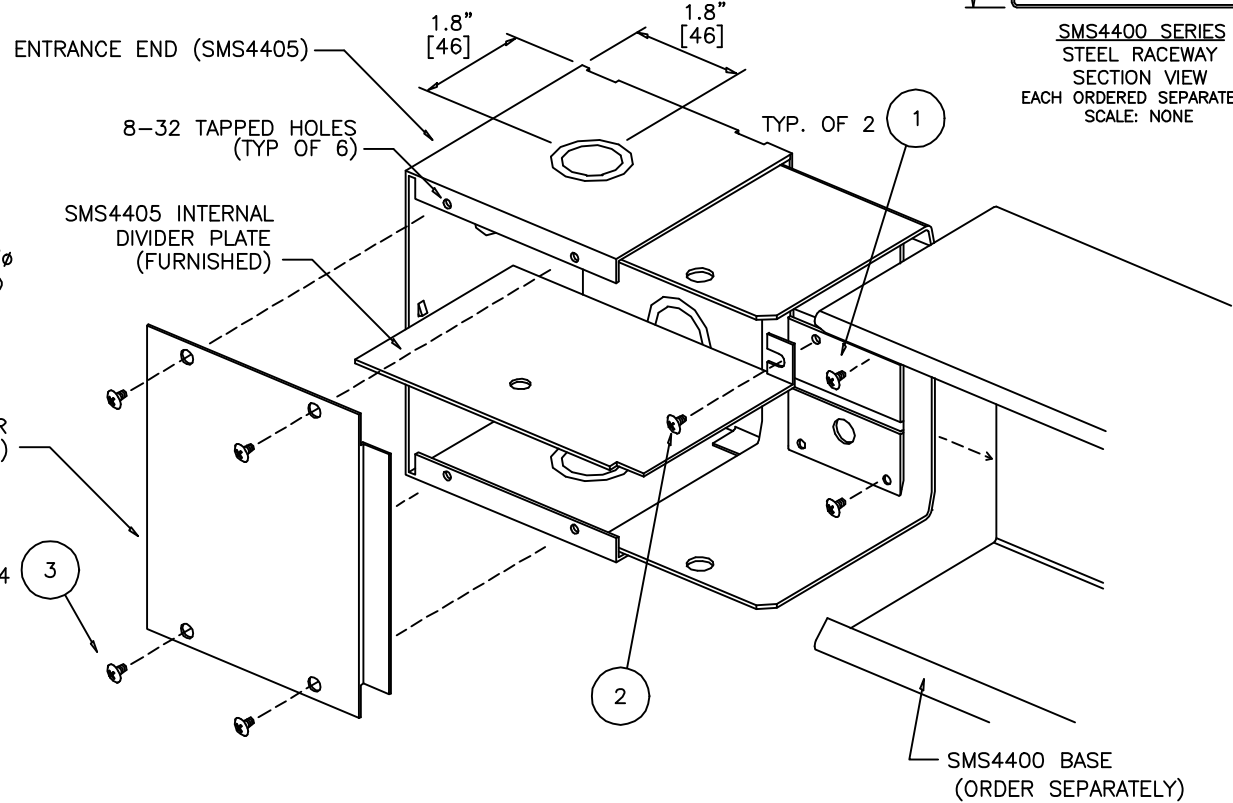

ASSEMBLY INSTRUCTIONS

1. SLIDE ENTRANCE END INTO END OF SMS4400 BASE SECTION. SECURE USING TWO 8-32 X 3/16" PAN HEAD SCREWS.
2. FASTEN INTERNAL DIVIDER PLATE TO ENTRANCE END USING ONE 8-32 X 3/16" PAN HEAD SCREW.
3. SECURE ENTRANCE END COVER USING FOUR 8-32 X 3/16" PAN HEAD SCREWS.
 (ASSEMBLY FASTENERS FURNISHED).

FILENAME: 4405A.DWG



MONO-SYSTEMS, INC.
UNIQUE CABLE DISTRIBUTION SOLUTIONS
 4 INTERNATIONAL DRIVE
 RYE BROOK, NEW YORK 10573
 PHONE: (914)-934-2075
 FAX: (914)-934-2190

WIRE CLIP — (SMS4406)

SCALE: NONE

GALVANIZED STEEL — UNPAINTED

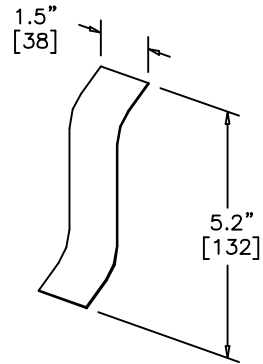

WIRE CLIP — (SMS4406)

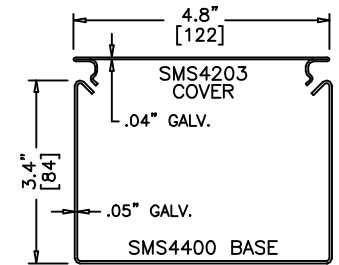
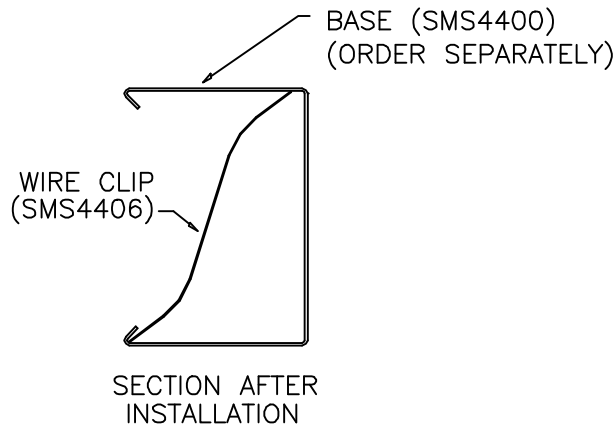

SMS4400 SERIES
STEEL RACEWAY
SECTION VIEW
 EACH ORDERED SEPARATELY
 SCALE: NONE

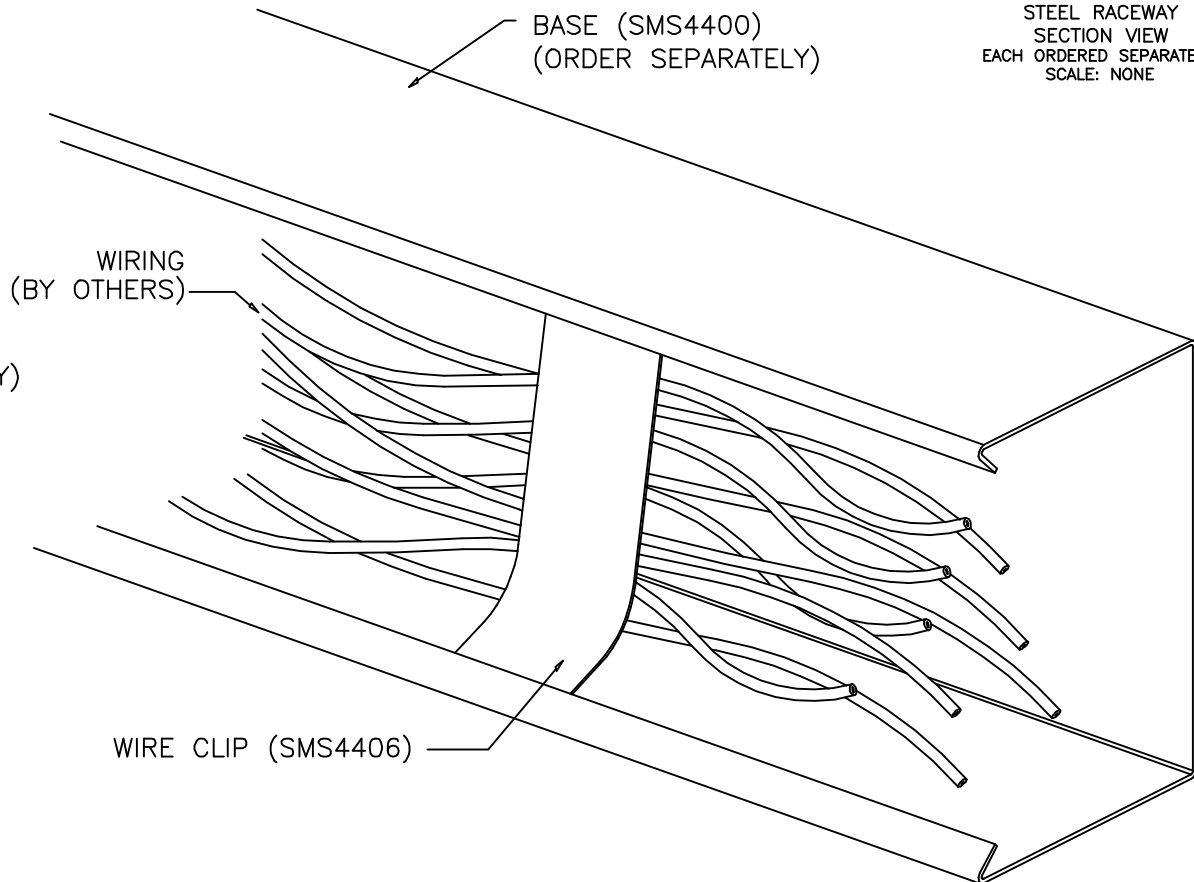

ASSEMBLY INSTRUCTIONS

1. POSITION WIRE CLIP TO HOLD WIRING INTO PLACE. TERMINATE AND ENCLOSE ALL WIRING PER NEC AND LOCAL CODES.

FILENAME: 4406A.DWG



MONO-SYSTEMS, INC.
UNIQUE CABLE DISTRIBUTION SOLUTIONS
 4 INTERNATIONAL DRIVE
 RYE BROOK, NEW YORK 10573
 PHONE: (914)-934-2075
 FAX: (914)-934-2190

DIVIDER STRIP – 5' [1.5m] (SMS4407)

SCALE: NONE

.05" THICK GALV.
 (PAINTED ON ONE SIDE FOR IDENTIFICATION)

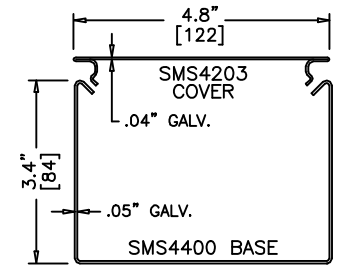

SMS4400 SERIES
 STEEL RACEWAY
 SECTION VIEW
 EACH ORDERED SEPARATELY
 SCALE: NONE

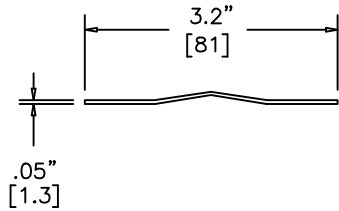

DIVIDER STRIP – (SMS4407)

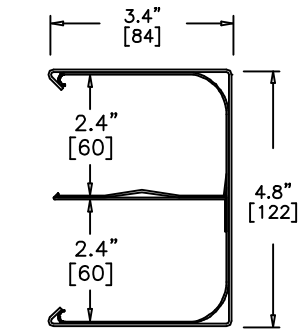

INTERNAL SECTION
 AFTER INSTALLATION

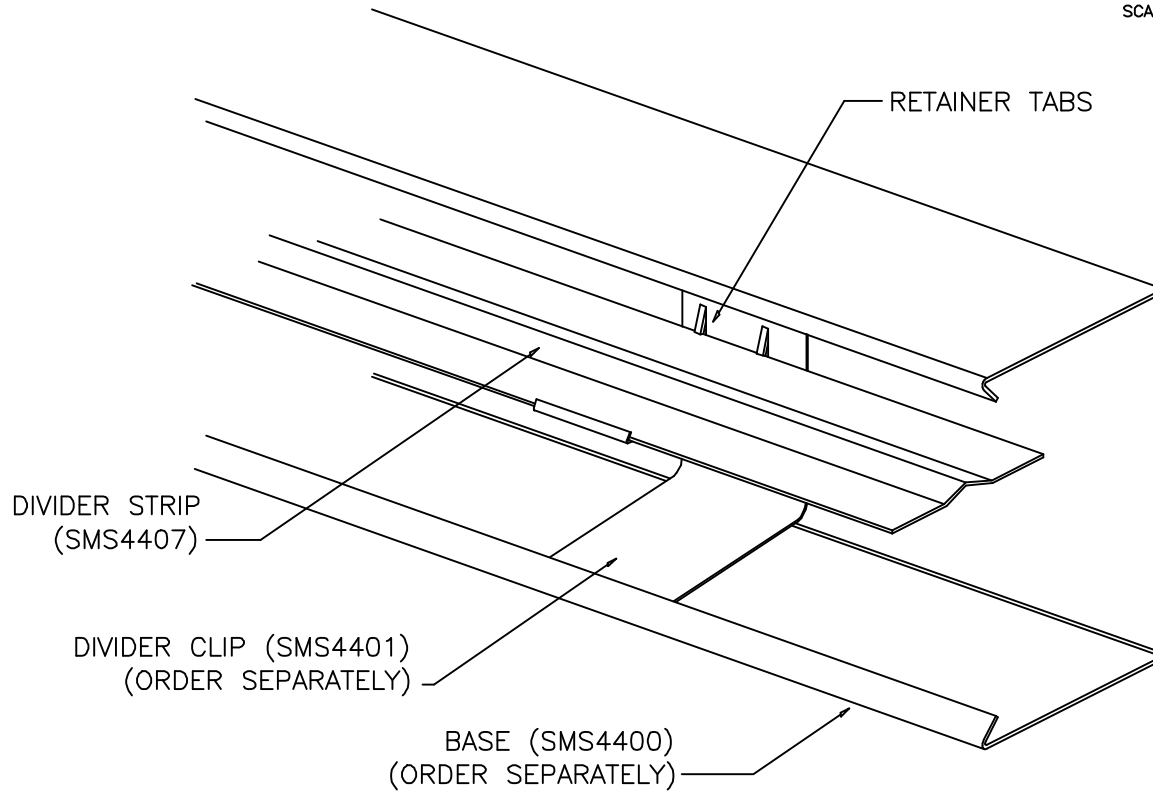

ASSEMBLY INSTRUCTIONS

1. POSITION DIVIDER STRIP INTO PLACE. SNAP INTO RETAINER TABS AS SHOWN TO SECURE DIVIDER STRIP IN PLACE. (PUSH RETAINER TABS BACK IN TO REMOVE DIVIDER STRIP IF REQUIRED)

FILENAME: 4407A.DWG



MONO-SYSTEMS, INC.
 UNIQUE CABLE DISTRIBUTION SOLUTIONS
 4 INTERNATIONAL DRIVE
 RYE BROOK, NEW YORK 10573
 PHONE: (914)-934-2075
 FAX: (914)-934-2190

COVER CLIP — (SMS4408)

SCALE: NONE

AVAILABLE IN STANDARD GRAY OR IVORY
 (ADD "-I" SUFFIX TO SPECIFY IVORY)

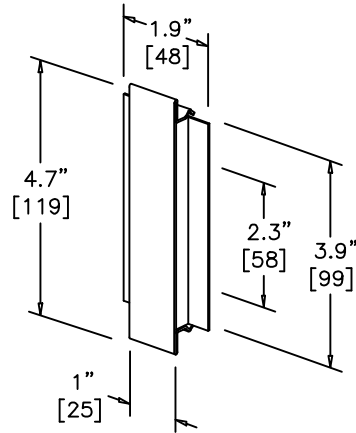

COVER CLIP — (SMS4408)

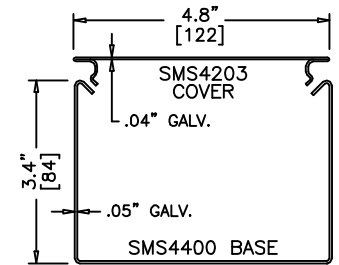

SMS4400 SERIES
 STEEL RACEWAY
 SECTION VIEW
 EACH ORDERED SEPARATELY
 SCALE: NONE

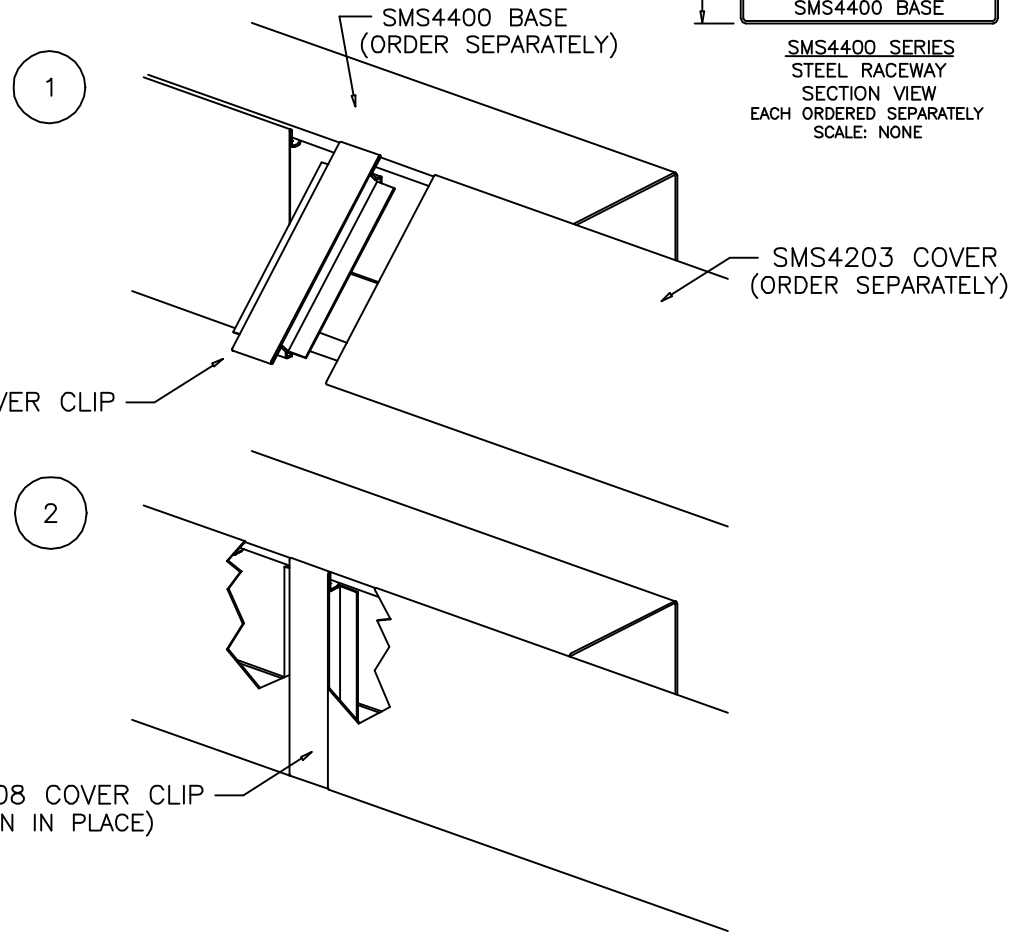

ASSEMBLY INSTRUCTIONS

1. INSERT ONE EDGE OF COVER CLIP UNDER LIP OF SMS4400 BASE.
2. FIRMLY PRESS COVER CLIP INTO PLACE ENSURING THAT BOTH SIDES ARE COMPLETELY SNAPPED INTO BASE SECTION.



90° FLAT ELBOW (SMS4409)

SCALE: NONE

AVAILABLE IN STANDARD GRAY OR IVORY
 (ADD "-I" SUFFIX TO SPECIFY IVORY)

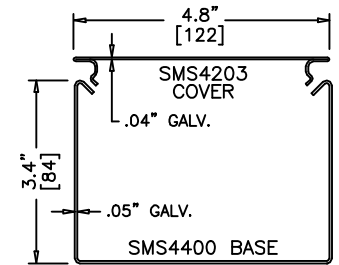

SMS4400 SERIES
STEEL RACEWAY
 SECTION VIEW
 EACH ORDERED SEPARATELY
 SCALE: NONE

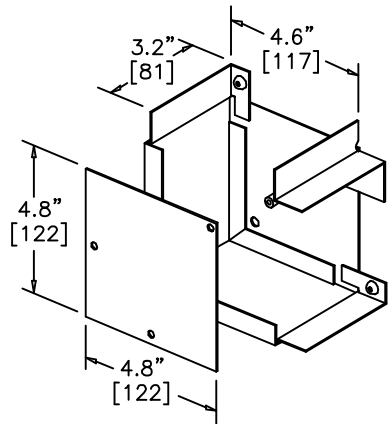

90° FLAT ELBOW (SMS4409)

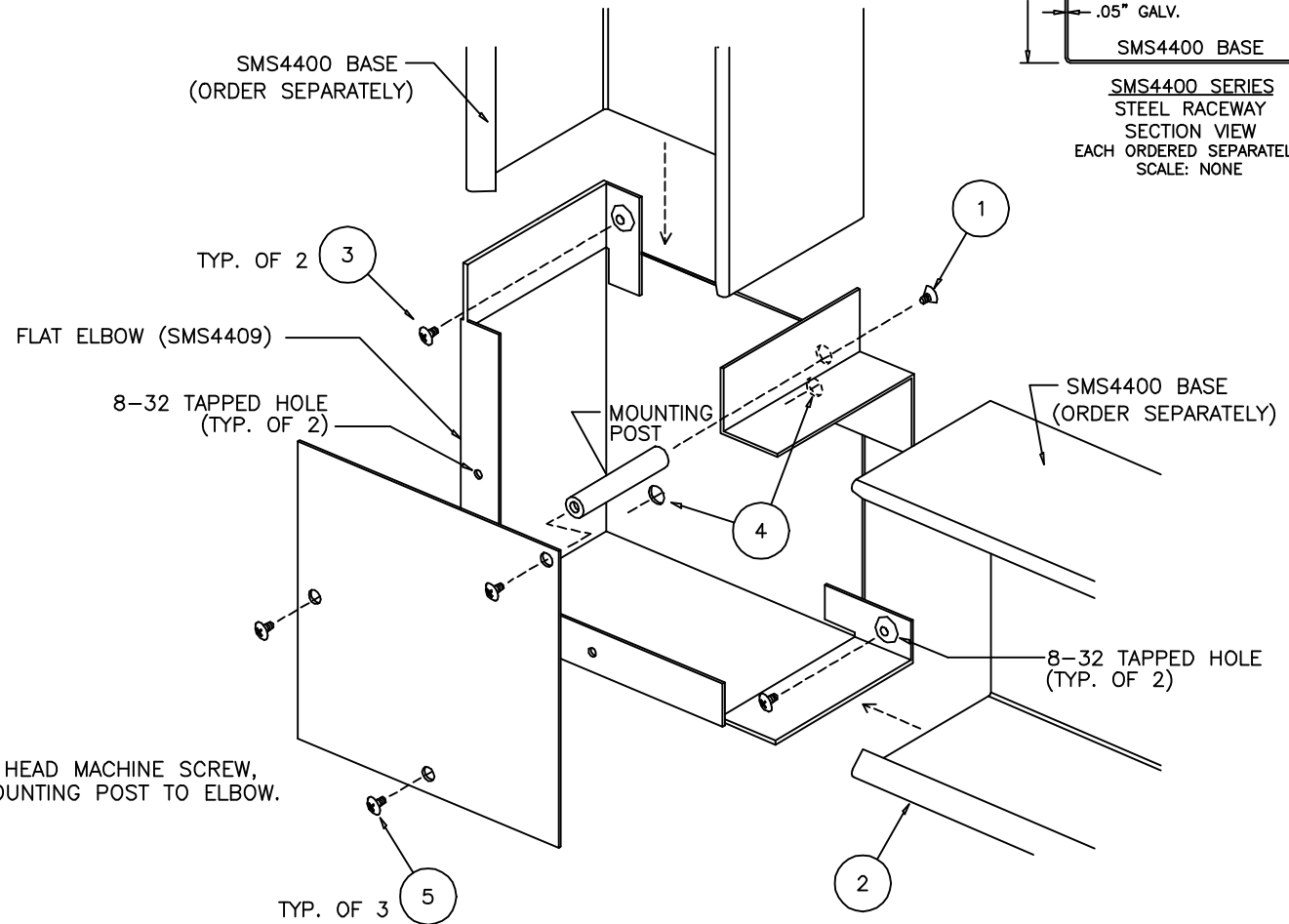

ASSEMBLY INSTRUCTIONS

1. USING FURNISHED 8-32x3/16" FLAT HEAD MACHINE SCREW, SECURE 2.3" LONG 8-32 TAPPED MOUNTING POST TO ELBOW.
2. SLIDE EXTERNAL 90° ELBOW INTO ENDS OF SMS4400 BASE SECTIONS.
3. SECURE ELBOW TO BASE SECTIONS USING TWO 8-32 X 3/16" PAN HEAD SCREWS (FURNISHED).
4. SECURE FLAT ELBOW TO MOUNTING SURFACE WITH SCREWS SUPPLIED BY OTHERS.
5. THREE FURNISHED 8-32 X 3/16" PAN HEAD SCREWS ARE USED TO SECURE COVER TO FLAT ELBOW.

FILENAME: 4409A.DWG



MONO-SYSTEMS, INC.
 UNIQUE CABLE DISTRIBUTION SOLUTIONS
 4 INTERNATIONAL DRIVE
 RYE BROOK, NEW YORK 10573
 PHONE: (914)-934-2075
 FAX: (914)-934-2190

Mono-Systems, Inc.
SnapMark (tm)
SMS4400 SERIES

TEE — (SMS4410)

SCALE: NONE

AVAILABLE IN STANDARD GRAY OR IVORY
 (ADD "-I" SUFFIX TO SPECIFY IVORY)

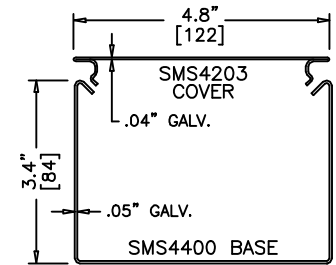

SMS4400 SERIES
STEEL RACEWAY
 SECTION VIEW
 EACH ORDERED SEPARATELY
 SCALE: NONE

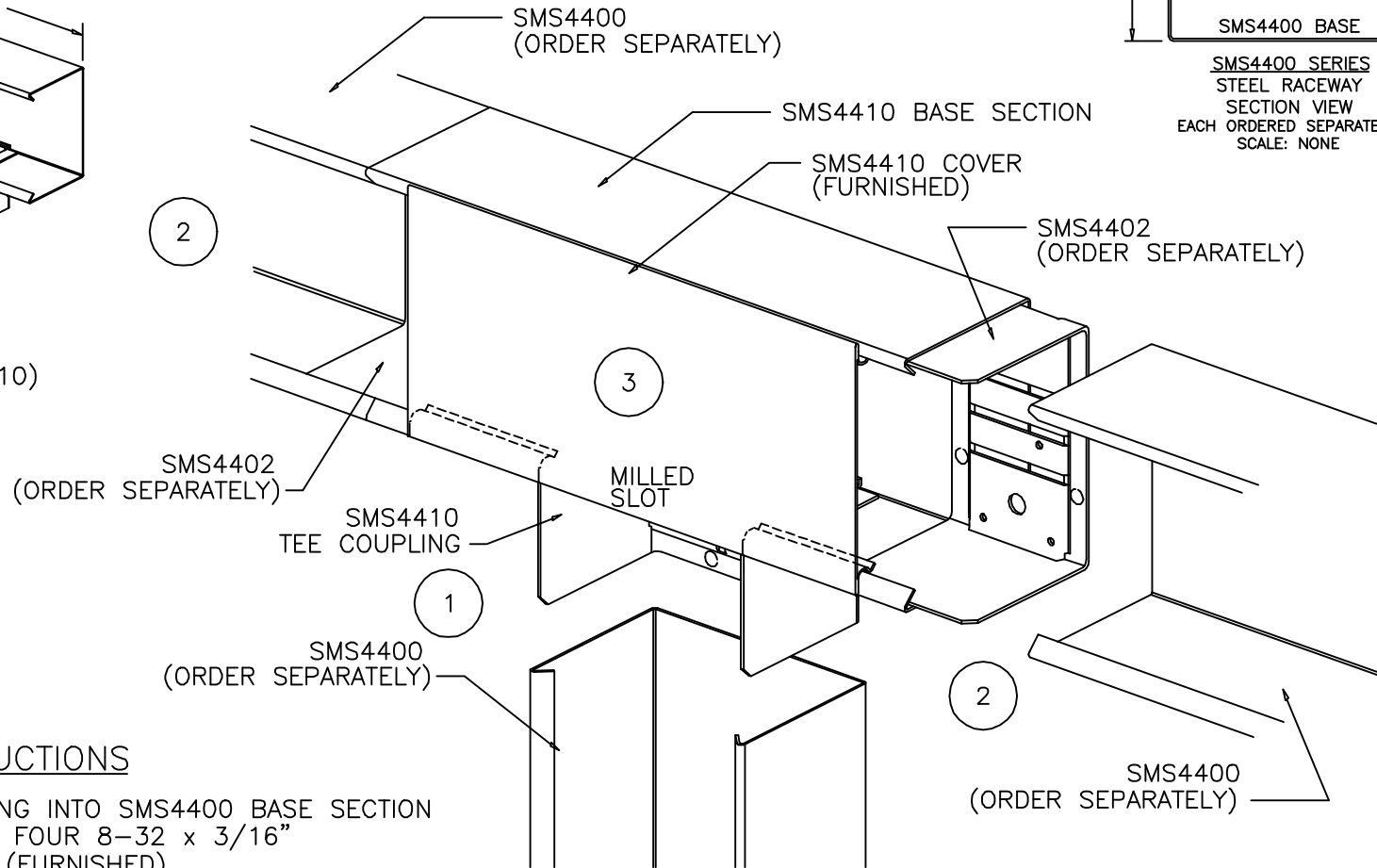
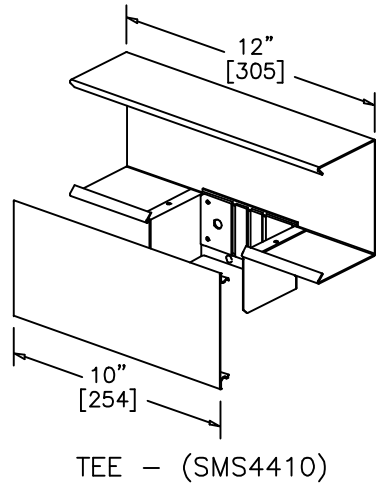

ASSEMBLY INSTRUCTIONS

1. INSERT TEE COUPLING INTO SMS4400 BASE SECTION AND SECURE USING FOUR 8-32 x 3/16" PAN HEAD SCREWS (FURNISHED)
2. CONNECT SMS4410 TO BASE SECTION USING SMS4402 COUPLINGS (TWO PLACES), ORDER SMS4402 COUPLINGS SEPARATELY.
3. ALIGN TEE COVER MILLED SLOT WITH TEE COUPLING, AND SNAP INTO PLACE.

FILENAME: 4410A.DWG



MONO-SYSTEMS, INC.
UNIQUE CABLE DISTRIBUTION SOLUTIONS
 4 INTERNATIONAL DRIVE
 RYE BROOK, NEW YORK 10573
 PHONE: (914)-934-2075
 FAX: (914)-934-2190

DIVIDED TEE – (SMS4411)

SCALE: NONE

AVAILABLE IN STANDARD GRAY OR IVORY
 (ADD "-I" SUFFIX TO SPECIFY IVORY)

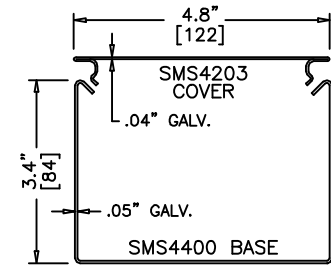

SMS4400 SERIES
STEEL RACEWAY
 SECTION VIEW
 EACH ORDERED SEPARATELY
 SCALE: NONE

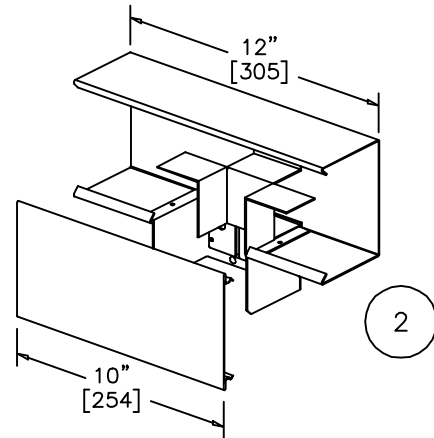

DIVIDED TEE – (SMS4411)

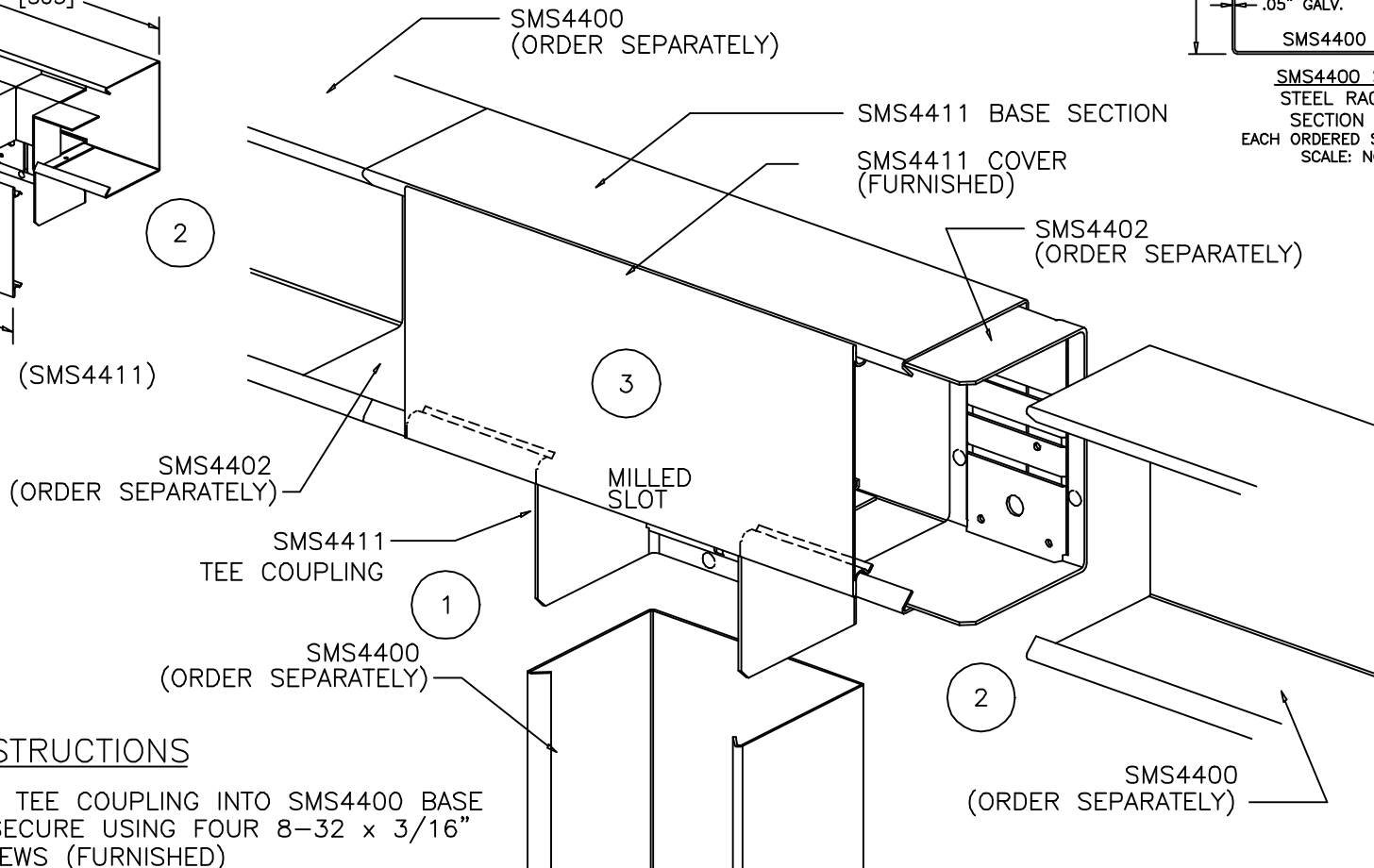

ASSEMBLY INSTRUCTIONS

1. INSERT DIVIDED TEE COUPLING INTO SMS4400 BASE SECTION AND SECURE USING FOUR 8-32 x 3/16" PAN HEAD SCREWS (FURNISHED)
2. CONNECT SMS4411 TO BASE SECTION USING SMS4402 COUPLINGS (TWO PLACES), ORDER SMS4402 COUPLINGS SEPARATELY.
3. ALIGN DIVIDED TEE COVER MILLED SLOT WITH TEE COUPLING, AND SNAP INTO PLACE.



MONO-SYSTEMS, INC.
UNIQUE CABLE DISTRIBUTION SOLUTIONS
 4 INTERNATIONAL DRIVE
 RYE BROOK, NEW YORK 10573
 PHONE: (914)-934-2075
 FAX: (914)-934-2190

INTERNAL 90° ELBOW (SMS4414)

SCALE: NONE

AVAILABLE IN STANDARD GRAY OR IVORY
 (ADD "-I" SUFFIX TO SPECIFY IVORY)

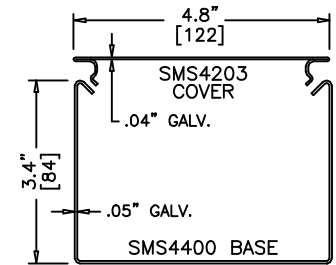

SMS4400 SERIES
STEEL RACEWAY
 SECTION VIEW
 EACH ORDERED SEPARATELY
 SCALE: NONE

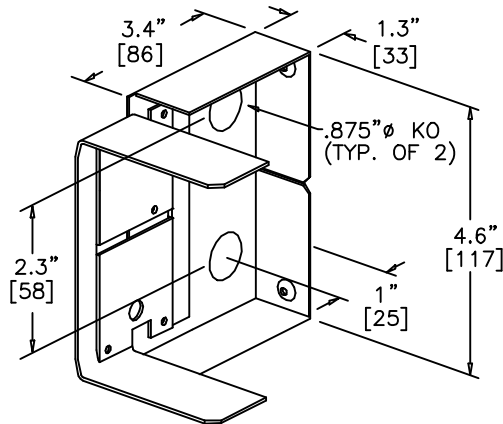

INTERNAL 90° ELBOW (SMS4414)

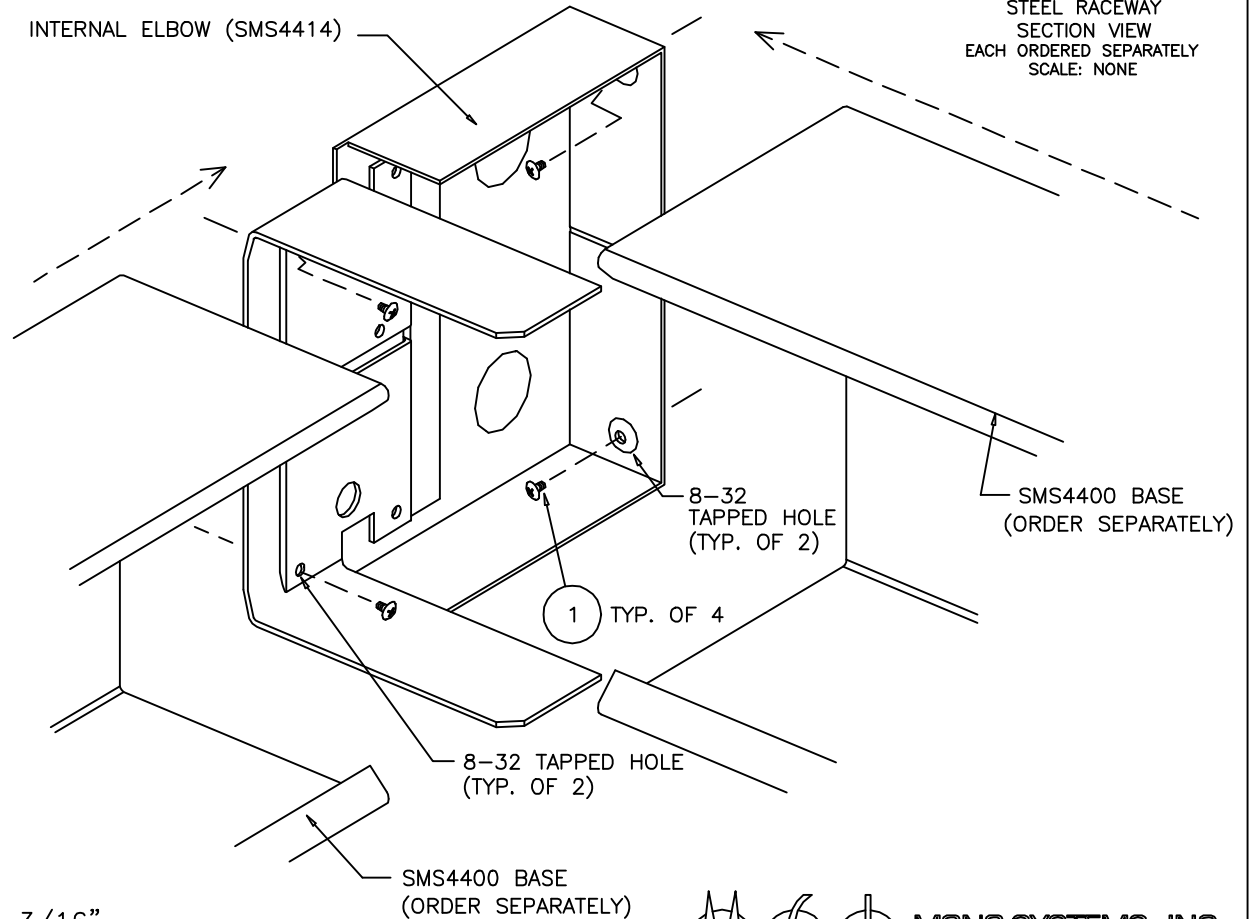

ASSEMBLY INSTRUCTIONS

1. SLIDE INTERNAL 90° ELBOW INTO ENDS OF SMS4400 BASE SECTIONS. SECURE IN PLACE USING FOUR 8-32 X 3/16" PAN HEAD SCREWS (FURNISHED).

FILENAME: 4414A.DWG



MONO-SYSTEMS, INC.
 UNIQUE CABLE DISTRIBUTION SOLUTIONS
 4 INTERNATIONAL DRIVE
 RYE BROOK, NEW YORK 10573
 PHONE: (914)-934-2075
 FAX: (914)-934-2190

INTERNAL/EXTERNAL 45° ELBOW (SMS4415)

SCALE: NONE

AVAILABLE IN STANDARD GRAY OR IVORY
 (ADD "-I" SUFFIX TO SPECIFY IVORY)

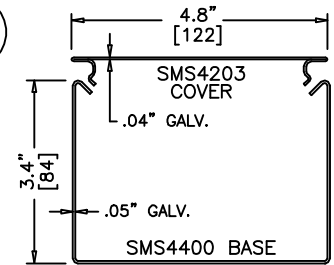

SMS4400 SERIES
 STEEL RACEWAY
 SECTION VIEW
 EACH ORDERED SEPARATELY
 SCALE: NONE

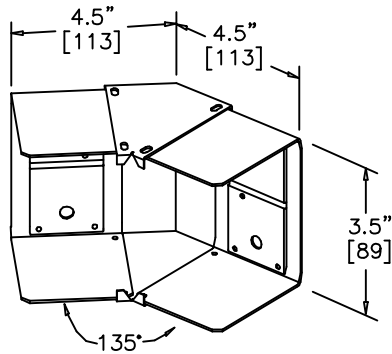

INT./EXT. 45° ELBOW (SMS4415)

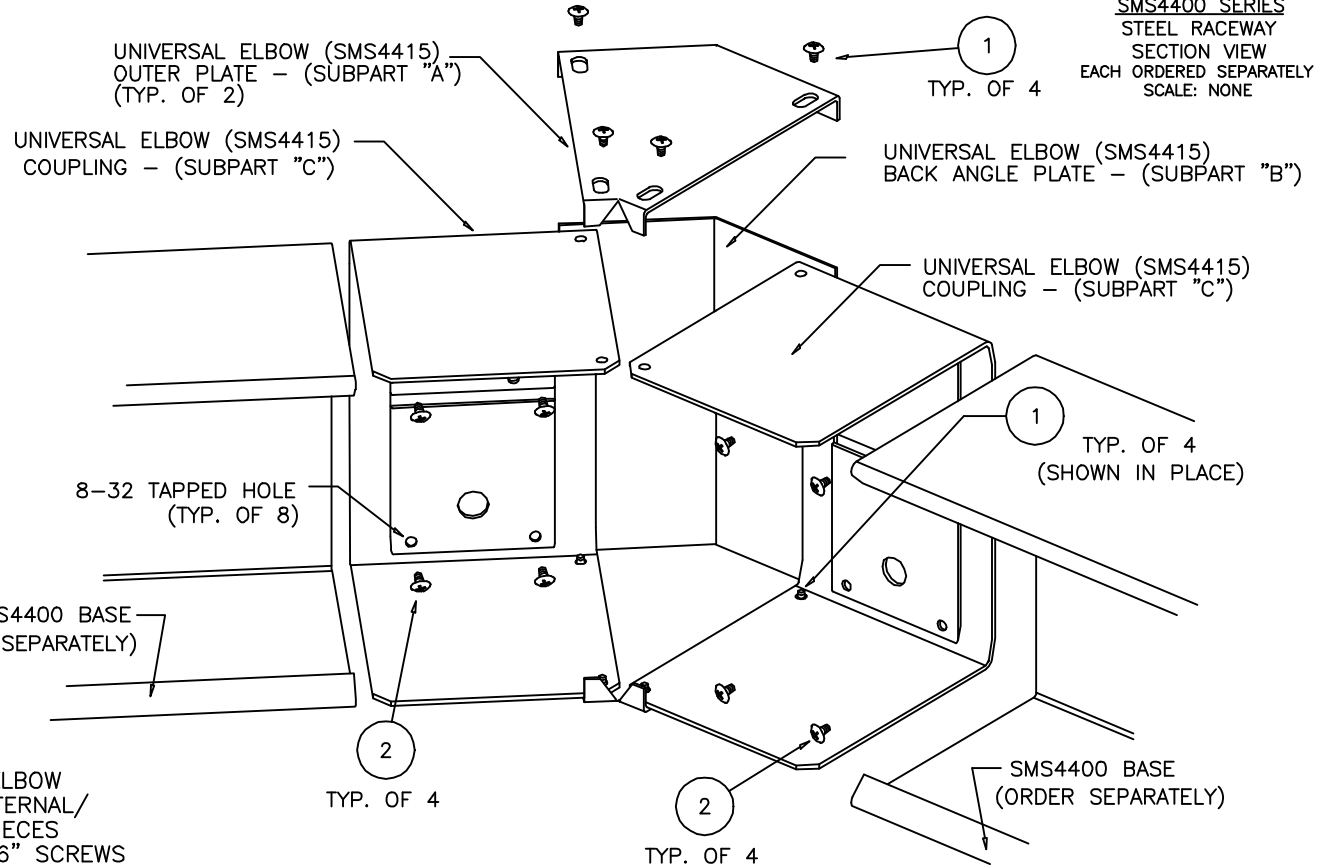

ASSEMBLY INSTRUCTIONS

1. ASSEMBLE BACK ANGLE PLATE AND ELBOW COUPLINGS TOGETHER IN DESIRED INTERNAL/EXTERNAL CONFIGURATION. SECURE PIECES TOGETHER USING EIGHT 8-32 X 3/16" SCREWS AND END CLIPS. (INTERNAL ASSEMBLY SHOWN)
2. INSERT ASSEMBLED 45° ELBOW INTO DESIRED ENDS OF SMS4400 BASE SECTION. SECURE TO RACEWAY USING FOUR 8-32 X 3/16" PAN HEAD SCREWS.

FILENAME: 4415A.DWG



MONO-SYSTEMS, INC.
 UNIQUE CABLE DISTRIBUTION SOLUTIONS
 4 INTERNATIONAL DRIVE
 RYE BROOK, NEW YORK 10573
 PHONE: (914)-934-2075
 FAX: (914)-934-2190

CONVERTER COUPLING (SMS4416)

SCALE: NONE

GALVANIZED STEEL – UNPAINTED

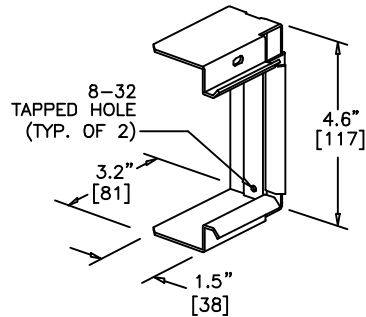

CONVERTER COUPLING (SMS4416)
 (4 QTY 8-32 x 3/16" FURNISHED)

NOTE:
 THE SMS4416 CONVERTER COUPLING IS OFFERED AS A SINGLE COMPONENT. REFER TO FIGURES 1, 2, 3, AND 4 FOR ASSEMBLY CONFIGURATION OPTIONS FOR USE WITH SMS4418 AND SMS4419.

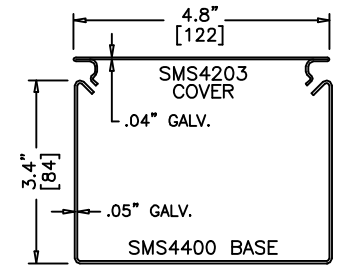

SMS4400 SERIES
STEEL RACEWAY
 SECTION VIEW
 EACH ORDERED SEPARATELY
 SCALE: NONE

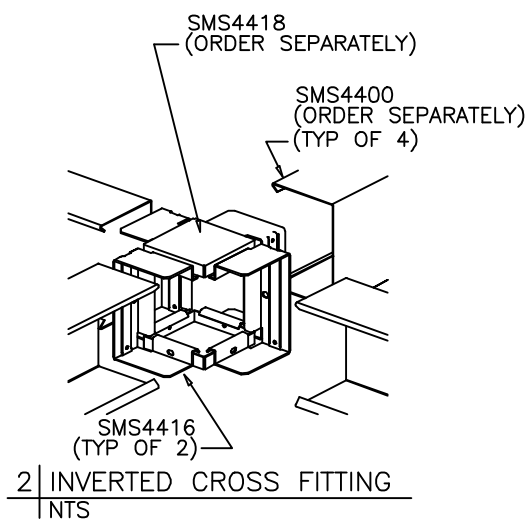
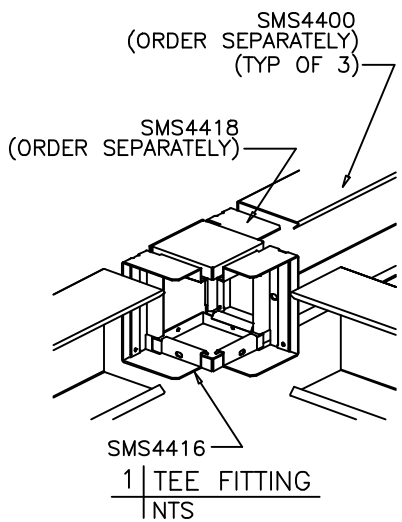

SMS4418 ASSEMBLY / CONFIGURATION OPTIONS

- A. THE SMS4418 UNIVERSAL INT./EXT. UNIVERSAL ELBOW IN COMBINATION WITH 1 SMS4416 CONVERTER COUPLING CAN BE USED TO ASSEMBLE A TEE FITTING.
- B. THE SMS4418 UNIVERSAL INT./EXT. UNIVERSAL ELBOW IN COMBINATION WITH 2 SMS4416 CONVERTER COUPLINGS CAN BE USED TO ASSEMBLE A CROSS OR INVERTED CROSS FITTING.

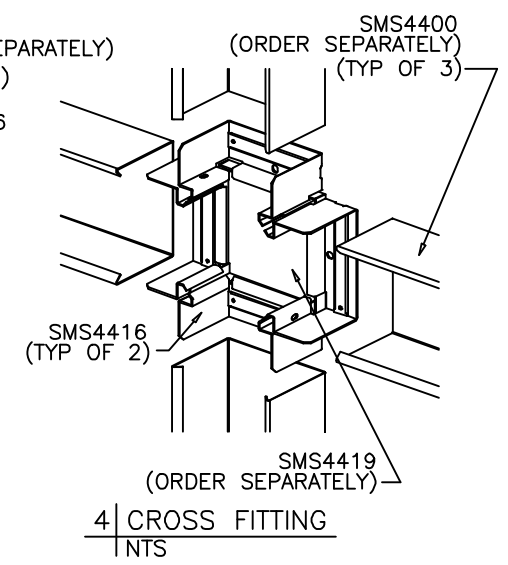
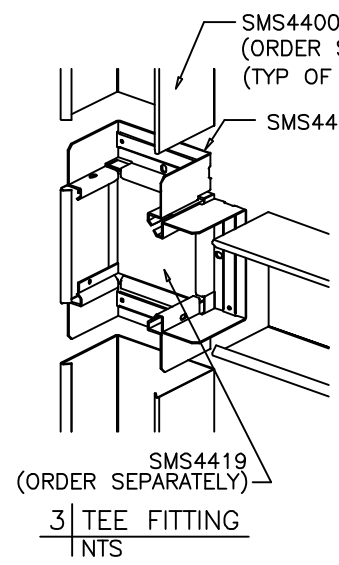

SMS4419 ASSEMBLY / CONFIGURATION OPTIONS

- C. THE SMS4419 UNIVERSAL FLAT ELBOW IN COMBINATION WITH 1 SMS4416 CONVERTER COUPLING CAN BE USED TO ASSEMBLE A TEE FITTING.
- D. THE SMS4419 UNIVERSAL FLAT ELBOW IN COMBINATION WITH 2 SMS4416 CONVERTER COUPLINGS CAN BE USED TO ASSEMBLE A CROSS FITTING.



MONO-SYSTEMS, INC.
UNIQUE CABLE DISTRIBUTION SOLUTIONS
 4 INTERNATIONAL DRIVE
 RYE BROOK, NEW YORK 10573
 PHONE: (914)-934-2075
 FAX: (914)-934-2190

90° INTERNAL/EXTERNAL ELBOW (SMS4418)

SCALE: NONE

AVAILABLE IN STANDARD GRAY OR IVORY
 (ADD "-I" SUFFIX TO SPECIFY IVORY)

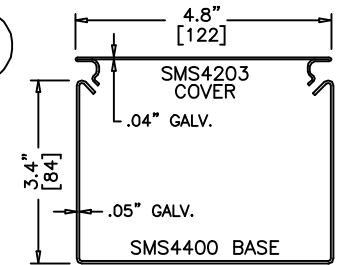

SMS4400 SERIES
STEEL RACEWAY
SECTION VIEW
 EACH ORDERED SEPARATELY
 SCALE: NONE

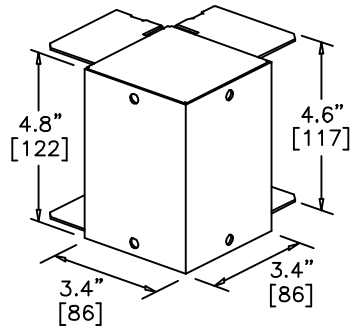

90° INT./EXT. ELBOW (SMS4418)
 (EXTERNAL CONFIGURATION)

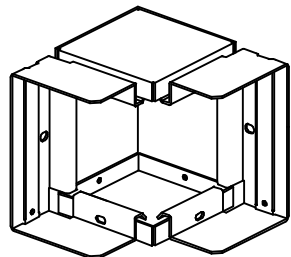

90° INT./EXT. ELBOW (SMS4418)
 (INTERNAL CONFIGURATION)

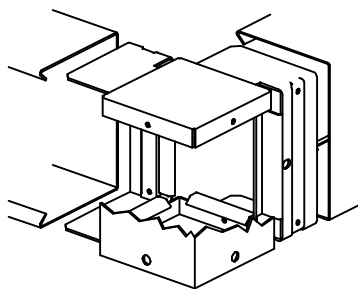

90° INT./EXT. ELBOW (SMS4418)
 (INVERTED EXTERNAL CONFIGURATION)

NOTES:

1. THE SMS4418 UNIVERSAL INT./EXT. UNIVERSAL ELBOW CAN BE USED AS PROVIDED FOR THE FOLLOWING.
A. EXTERNAL ELBOW
B. INTERNAL ELBOW
C. INVERTED ELBOW
2. THE SMS4418 UNIVERSAL INT./EXT. UNIVERSAL ELBOW IN COMBINATION WITH ONE ADDITIONAL SMS4416 CONVERTER COUPLING CAN BE USED TO ASSEMBLE THE FOLLOWING.
D. TEE FITTING
E. INVERTED TEE FITTING
3. THE SMS4418 UNIVERSAL INT./EXT. UNIVERSAL ELBOW IN COMBINATION WITH TWO ADDITIONAL SMS4416 CONVERTER COUPLINGS CAN BE USED TO ASSEMBLE THE FOLLOWING.
F. CROSS FITTING
G. INVERTED CROSS FITTING

SEE 4416A.DWG FOR DETAILS

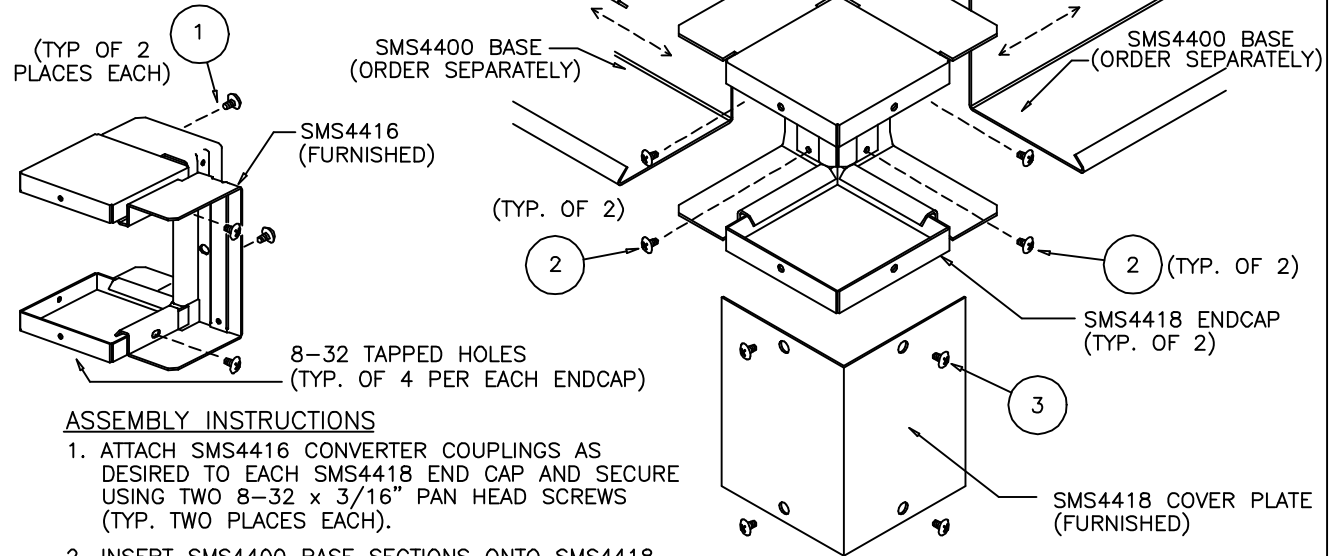

ASSEMBLY INSTRUCTIONS

1. ATTACH SMS4416 CONVERTER COUPLINGS AS DESIRED TO EACH SMS4418 END CAP AND SECURE USING TWO 8-32 x 3/16" PAN HEAD SCREWS (TYP. TWO PLACES EACH).
2. INSERT SMS4400 BASE SECTIONS ONTO SMS4418 ASSEMBLY AND SECURE USING TWO 8-32 x 3/16" PAN HEAD SCREWS (TYP. TWO PLACES EACH.).
3. SECURE ELBOW COVER PLATE IN PLACE USING FOUR 8-32 x 1/8" FLAT HEAD SCREWS.

ALL ASSEMBLY FASTENERS FURNISHED.



MONO-SYSTEMS, INC.
UNIQUE CABLE DISTRIBUTION SOLUTIONS
 4 INTERNATIONAL DRIVE
 RYE BROOK, NEW YORK 10573
 PHONE: (914)-934-2075
 FAX: (914)-934-2190

UNIVERSAL 90° FLAT ELBOW (SMS4419)

SCALE: NONE

AVAILABLE IN STANDARD GRAY OR IVORY
 (ADD "-I" SUFFIX TO SPECIFY IVORY)

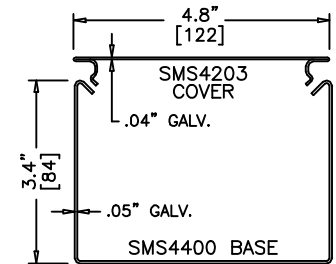

SMS4400 SERIES
STEEL RACEWAY
 SECTION VIEW
 EACH ORDERED SEPARATELY
 SCALE: NONE

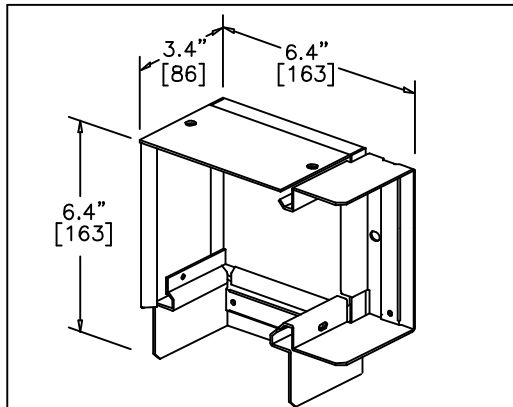

UNIVERSAL 90° FLAT ELBOW (SMS4419)



SMS4419 SHOWN AS STRAIGHT THROUGH

NOTES:

1. THE SMS4419 UNIVERSAL FLAT ELBOW CAN BE USED AS PROVIDED TO ASSEMBLE A FLAT ELBOW AND A STRAIGHT THROUGH.
2. THE SMS4419 UNIVERSAL FLAT ELBOW IN COMBINATION WITH ONE ADDITIONAL SMS4416 CONVERTER COUPLING CAN BE USED TO ASSEMBLE A TEE FITTING.
3. THE SMS4419 UNIVERSAL FLAT ELBOW IN COMBINATION WITH TWO ADDITIONAL SMS4416 CONVERTER COUPLINGS CAN BE USED TO ASSEMBLE A CROSS FITTING.

SEE 4416A.DWG FOR DETAILS

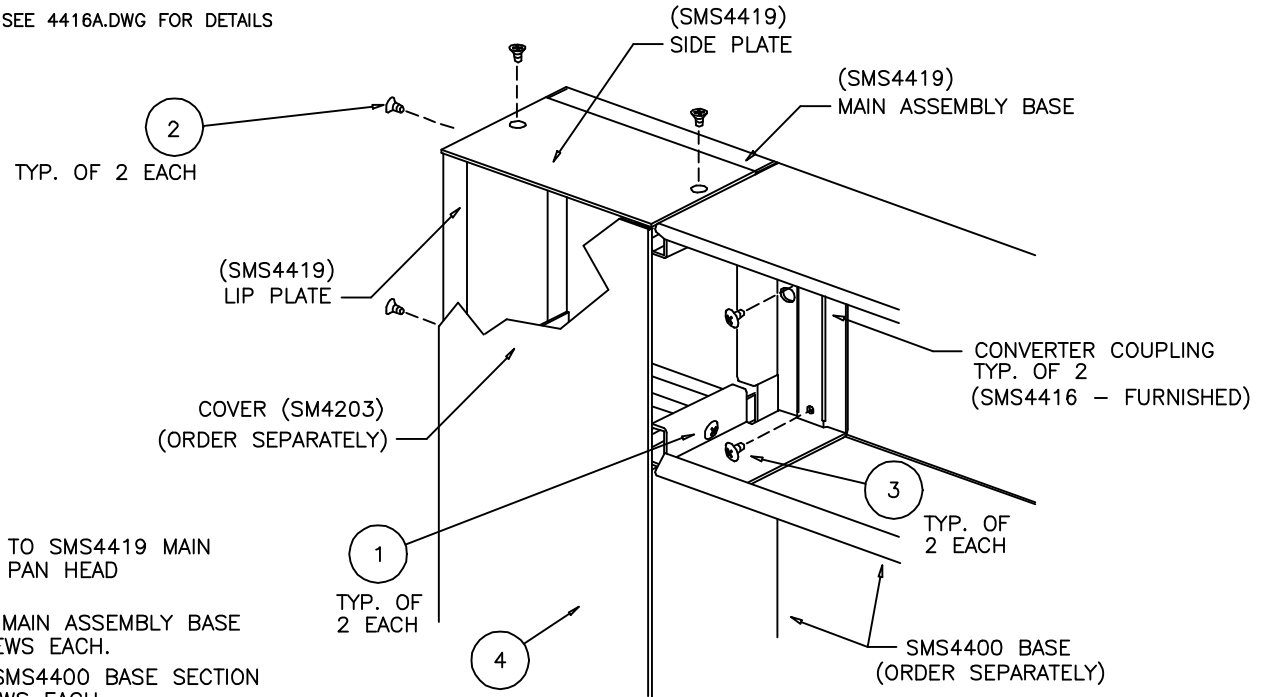

ASSEMBLY INSTRUCTIONS

1. FASTEN CONVERTER COUPLINGS AS DESIRED TO SMS4419 MAIN ASSEMBLY BASE USING TWO 8-32 x 3/16" PAN HEAD SCREWS (2 PLACES TYP.).
 2. FASTEN LIP AND SIDE PLATES TO SMS4419 MAIN ASSEMBLY BASE USING TWO 8-32 X 3/16" FLAT HEAD SCREWS EACH.
 3. ATTACH THE SMS4419 ASSEMBLY TO EACH SMS4400 BASE SECTION USING TWO 8-32 X 3/16" PAN HEAD SCREWS EACH.
 4. ATTACH SMS4403 COVER TO COMPLETED ASSEMBLY, PASSING OVER LIP PLATE AS SHOWN.
- ALL ASSEMBLY FASTENERS FURNISHED

FILENAME: 4419A.DWG



MONO-SYSTEMS, INC.
 UNIQUE CABLE DISTRIBUTION SOLUTIONS
 4 INTERNATIONAL DRIVE
 RYE BROOK, NEW YORK 10573
 PHONE: (914)-934-2075
 FAX: (914)-934-2190

WALL BOX FEED (SMS4430)

SCALE: NONE

AVAILABLE IN STANDARD GRAY OR IVORY
 (ADD "-I" SUFFIX TO SPECIFY IVORY)

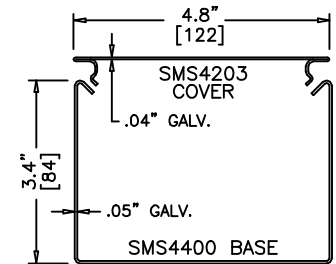

SMS4400 SERIES
STEEL RACEWAY
SECTION VIEW
 EACH ORDERED SEPARATELY
 SCALE: NONE

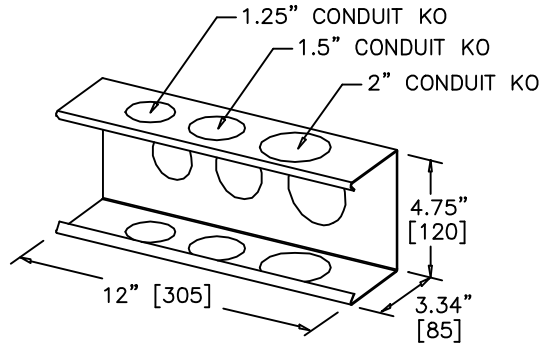

WALL BOX FEED (SMS4430)

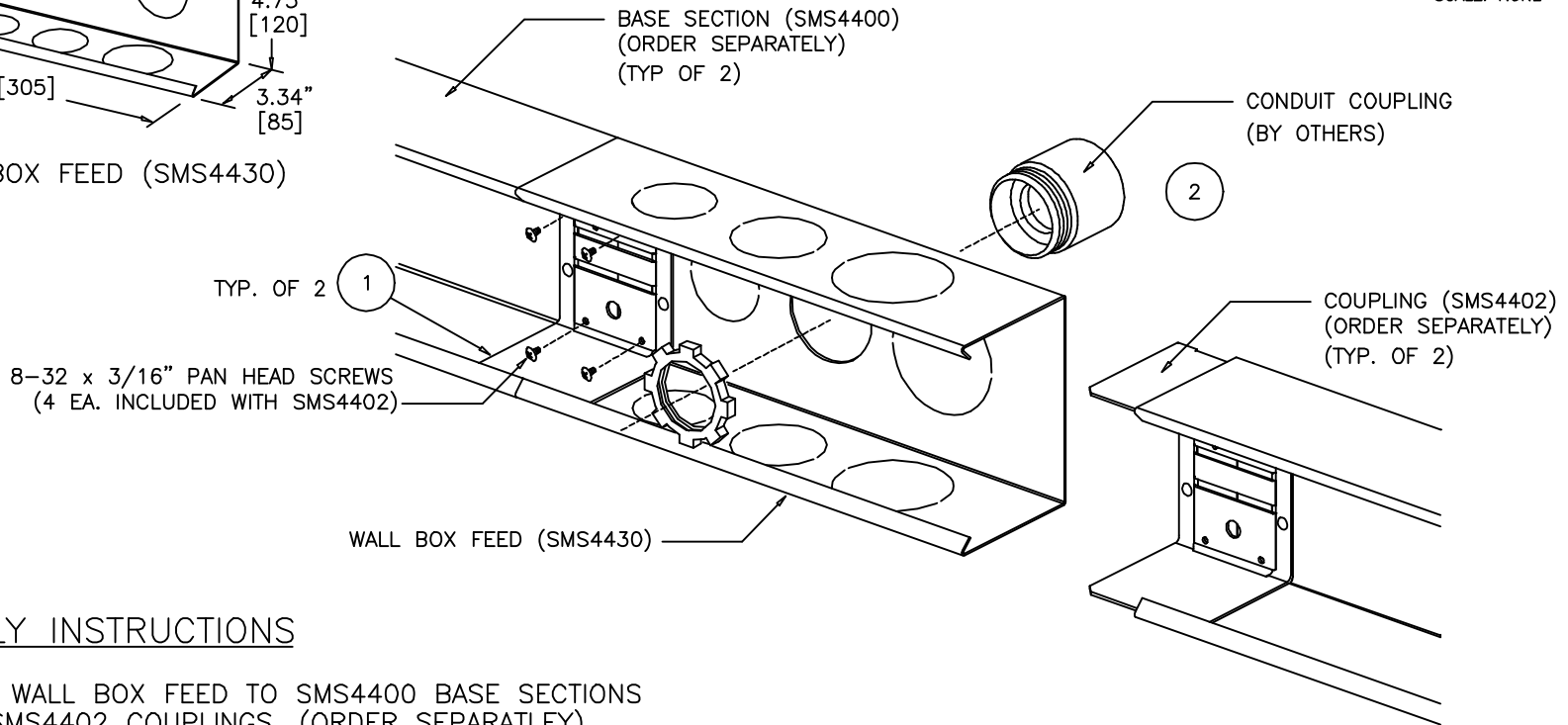

ASSEMBLY INSTRUCTIONS

1. SECURE WALL BOX FEED TO SMS4400 BASE SECTIONS USING SMS4402 COUPLINGS. (ORDER SEPARATELY)
2. SECURE CONDUIT COUPLINGS (BY OTHERS) THROUGH DESIRED KNOCK OUT.
3. TERMINATE AND ENCLOSE ALL WIRING PER NEC AND LOCAL CODES.

ORDER SPLICE CONNECTORS SEPARATELY
 P/N: SMS4402 - 2 REQUIRED



MONO-SYSTEMS, INC.
UNIQUE CABLE DISTRIBUTION SOLUTIONS
 4 INTERNATIONAL DRIVE
 RYE BROOK, NEW YORK 10573
 PHONE: (914)-934-2075
 FAX: (914)-934-2190

C-HANGER (SMS4464)

SCALE: NONE

AVAILABLE IN STANDARD GRAY OR IVORY
 (ADD "-I" SUFFIX TO SPECIFY IVORY)

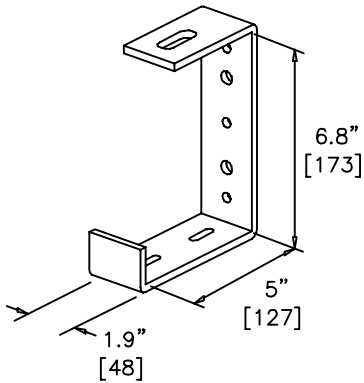

C-HANGER (SMS4464)
 OVERALL DIMENSIONS

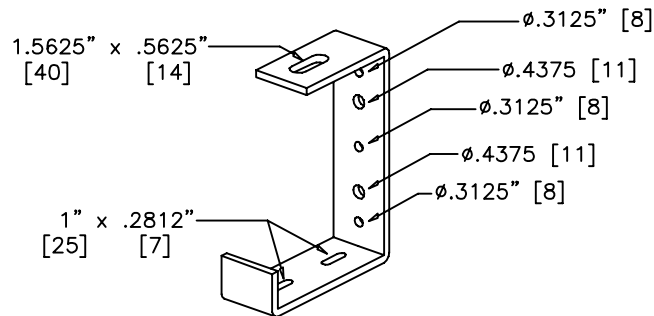

C-HANGER (SMS4464)
 MOUNTING HOLE DIMENSIONS

ASSEMBLY INSTRUCTIONS

1. FASTEN C-HANGERS TO 3/8" THREADED ROD USING 3/8" WASHERS AND NUTS, HANGERS ARE TO BE INSTALLED @ 5' [122m] MAXIMUM CENTERS.
2. THRU FIELD DRILLED HOLES, FASTEN SMS4400 BASE SECTIONS TO EACH C-HANGER USING TWO 10-32 x 5/8" MACHINE SCREWS WITH WASHERS AND NUT.

FILENAME: 4464A.DWG

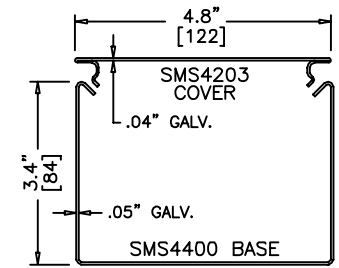

SMS4400 SERIES
 STEEL RACEWAY
 SECTION VIEW
 EACH ORDERED SEPARATELY
 SCALE: NONE

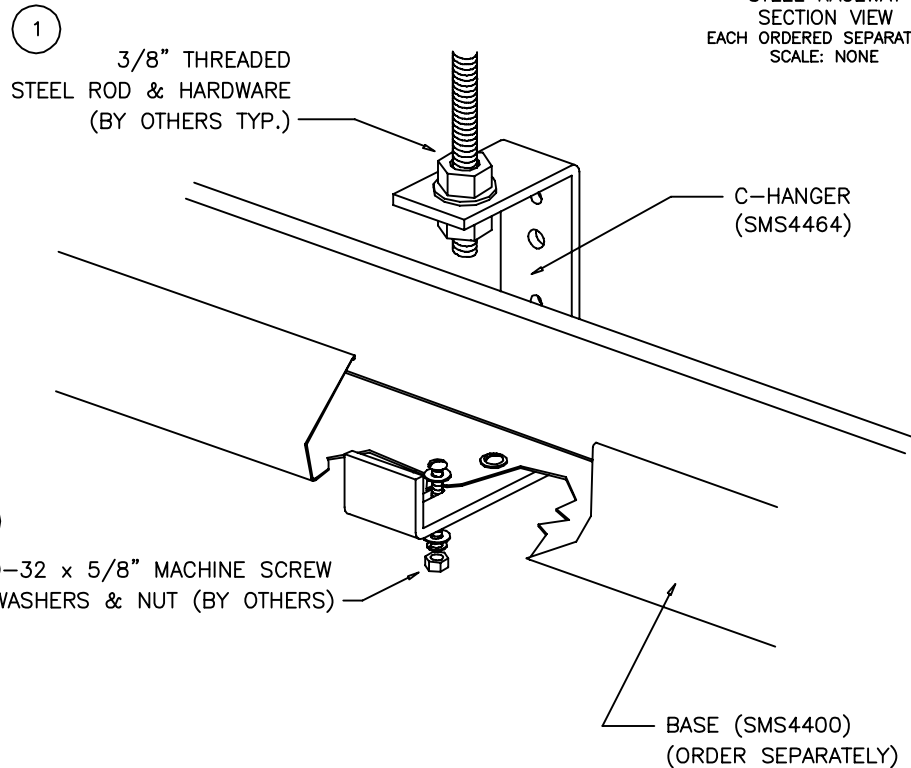

LOAD INFORMATION:
30 LBS. / 10FT. SECTION @ 5' [1.52m] MAXIMUM CENTERS.



MONO-SYSTEMS, INC.
 UNIQUE CABLE DISTRIBUTION SOLUTIONS
 4 INTERNATIONAL DRIVE
 RYE BROOK, NEW YORK 10573
 PHONE: (914)-934-2075
 FAX: (914)-934-2190

4400/4200 ADAPTER (SMS4473)

SCALE: NONE

AVAILABLE IN STANDARD GRAY OR IVORY
 (ADD "-I" SUFFIX TO SPECIFY IVORY)

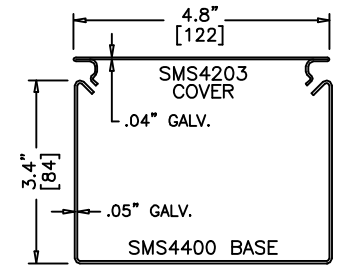

SMS4400 SERIES
 STEEL RACEWAY
 SECTION VIEW
 EACH ORDERED SEPARATELY
 SCALE: NONE

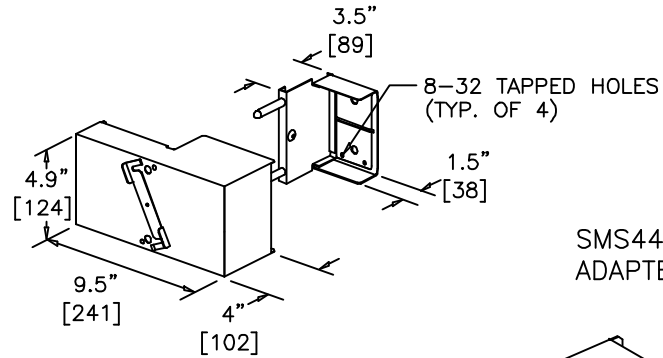

4400/4200 ADAPTER (SMS4473)

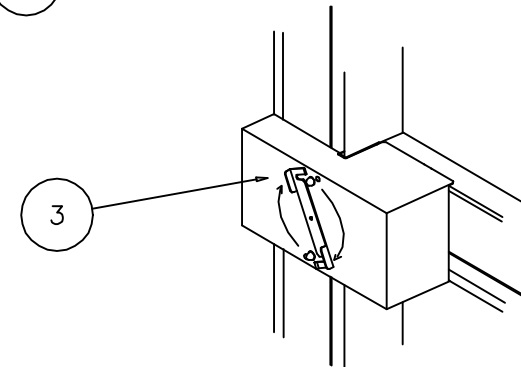
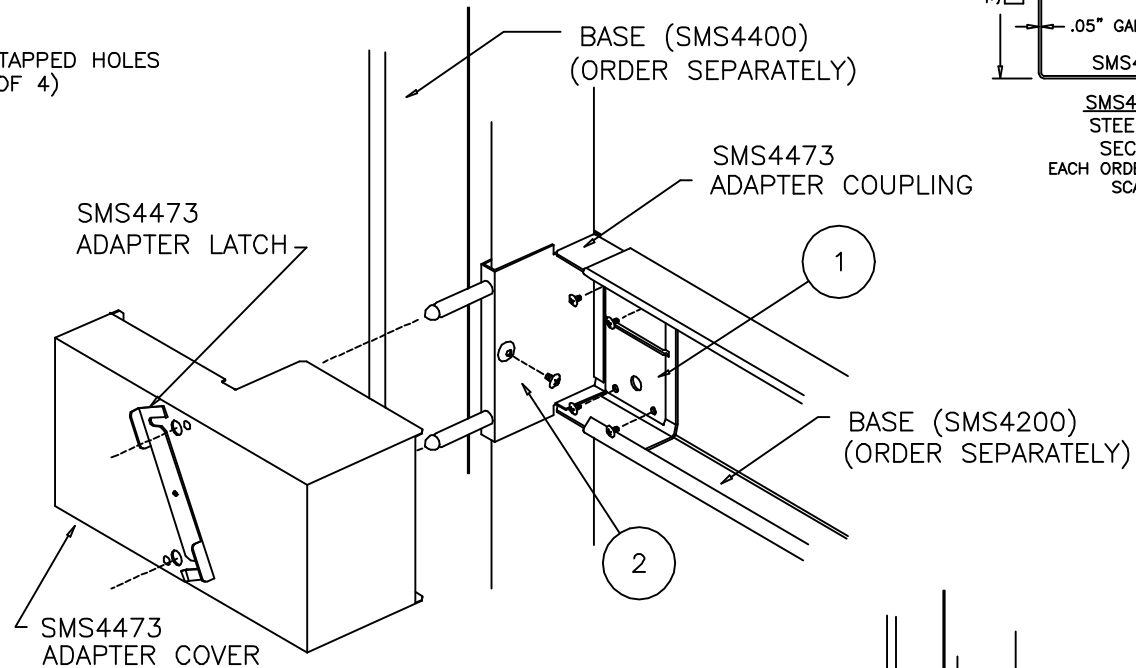

ASSEMBLED SMS4473

ASSEMBLY INSTRUCTIONS

1. INSERT ADAPTER COUPLING INTO END OF SMS4200 BASE SECTION TO BE JOINED. SECURE IN PLACE USING FOUR 8-32 X 3/16" PAN HEAD SCREWS.
2. SLIDE LIP OF CONNECTING CLIP OVER EDGE OF PERPENDICULAR SMS4400 RACEWAY AND SECURE USING ONE 10-32 X 3/16" PAN HEAD SCREW.
3. LOCATE THE SMS4474 COVER OVER THE ADJOINING RACEWAYS, SO THAT ATTACHMENT POSTS GO THROUGH THE COVER HOLES. ROTATE ADAPTER LATCH TO SECURE COVER.

FILENAME: 4473A.DWG



MONO-SYSTEMS, INC.
 UNIQUE CABLE DISTRIBUTION SOLUTIONS
 4 INTERNATIONAL DRIVE
 RYE BROOK, NEW YORK 10573
 PHONE: (914)-934-2075
 FAX: (914)-934-2190

4400/4400 ADAPTER (SMS4474)

SCALE: NONE

AVAILABLE IN STANDARD GRAY OR IVORY
 (ADD "-I" SUFFIX TO SPECIFY IVORY)

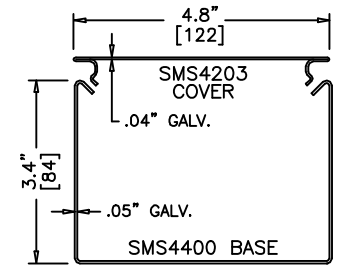

SMS4400 SERIES
STEEL RACEWAY
 SECTION VIEW
 EACH ORDERED SEPARATELY
 SCALE: NONE

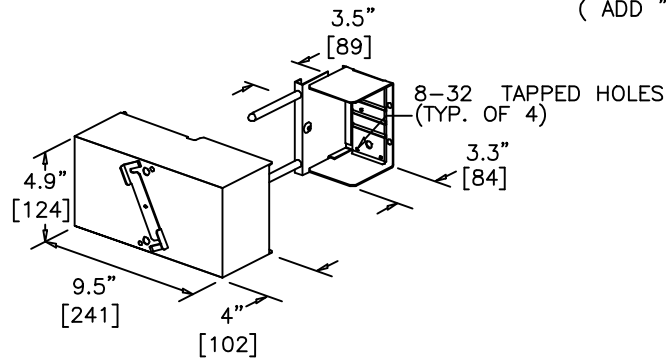

4400/4400 ADAPTER (SMS4474)

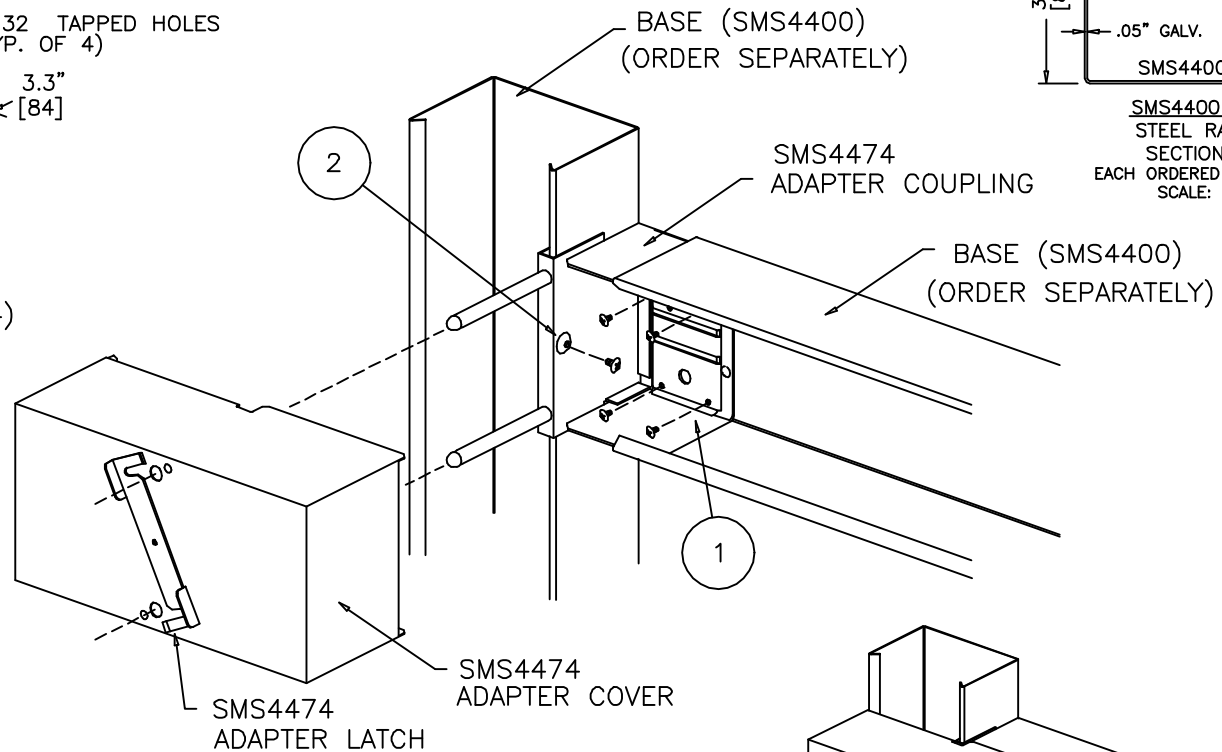

ASSEMBLY INSTRUCTIONS

1. INSERT ADAPTER COUPLING INTO END OF SMS4200 BASE SECTION TO BE JOINED. SECURE IN PLACE USING FOUR 8-32 X 3/16" PAN HEAD SCREWS.
2. SLIDE LIP OF CONNECTING CLIP OVER EDGE OF PERPENDICULAR SMS4400 RACEWAY AND SECURE USING ONE 10-32 X 3/16" PAN HEAD SCREW.
3. LOCATE THE SMS4474 COVER OVER THE ADJOINING RACEWAYS, SO THAT ATTACHMENT POSTS GO THROUGH THE COVER HOLES. ROTATE ADAPTER LATCH TO SECURE COVER.

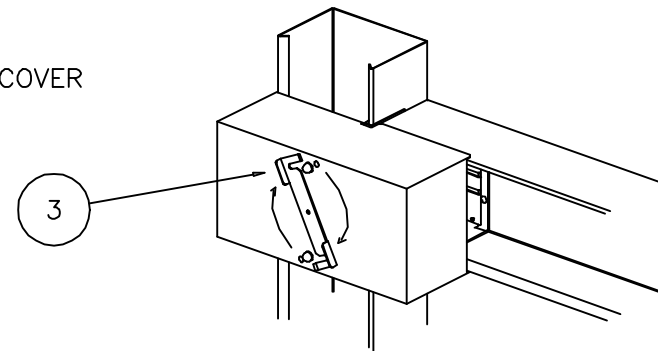

ASSEMBLED SMS4474



MONO-SYSTEMS, INC.
 UNIQUE CABLE DISTRIBUTION SOLUTIONS
 4 INTERNATIONAL DRIVE
 RYE BROOK, NEW YORK 10573
 PHONE: (914)-934-2075
 FAX: (914)-934-2190

PANEL CONNECTOR (SMS4486)

SCALE: NONE

AVAILABLE IN STANDARD GRAY OR IVORY
 (ADD "-I" SUFFIX TO SPECIFY IVORY)

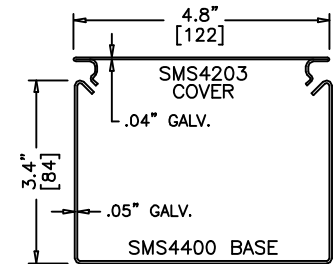

SMS4400 SERIES
STEEL RACEWAY
SECTION VIEW
 EACH ORDERED SEPARATELY
 SCALE: NONE

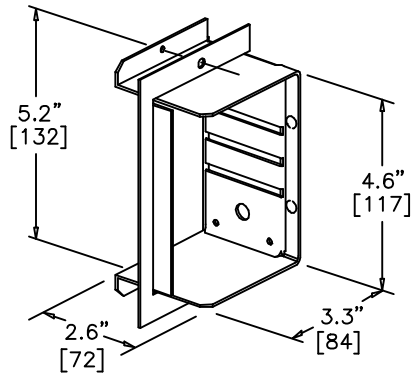

PANEL CONNECTOR (SMS4486)

BASE (SMS4400)
 (ORDER SEPARATELY)

COVER (SMS4403)
 (ORDER SEPARATELY)

PANEL CONNECTOR - COUPLING
 (SMS4486)

PANEL CONNECTOR CLIP
 (SMS4486)

TYP. OF 2

8-32 TAPPED HOLE
 (TYP. OF 2)

FIELD CUT OPENING
 & DRILL MTG. HOLES IN
 ENCLOSURE BOX OR J-BOX
 (SEE TEMPLATE)

NOTE: PANEL AND PANEL
 MODIFICATIONS BY OTHERS ...
 (SIMILAR FOR J-BOX)

TYP. OF 4

ASSEMBLY INSTRUCTIONS

1. POSITION PANEL CONECTOR COUPLING THROUGH OPENING IN ENCLOSURE BOX (BY OTHERS) SO THAT EMBOSSED 8-32 HOLES ARE ON THE EXTERIOR. SLIDE SMS4400 BASE ONTO PANEL CONNECTOR COUPLING AND SECURE WITH FOUR 8-32 x 3/16" PAN HEAD SCREWS.
2. ATTACH PANEL CONNECTOR CLIP AS SHOWN ON OUTSIDE OF PANEL BOX AND SECURE IN PLACE USING TWO 8-32 X 1/4" PAN HEAD SCREWS.



MONO-SYSTEMS, INC.
UNIQUE CABLE DISTRIBUTION SOLUTIONS
 4 INTERNATIONAL DRIVE
 RYE BROOK, NEW YORK 10573
 PHONE: (914)-934-2075
 FAX: (914)-934-2190

Mono-Systems, Inc.
SnapMark (tm)
SMS4400 SERIES

PANEL CONNECTOR (SMS4486)

SCALE: NONE

AVAILABLE IN STANDARD GRAY OR IVORY
 (ADD "-I" SUFFIX TO SPECIFY IVORY)

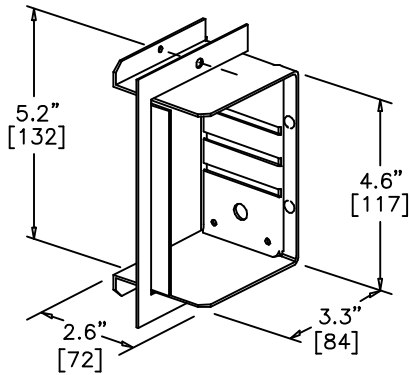

PANEL CONNECTOR (SMS4486)

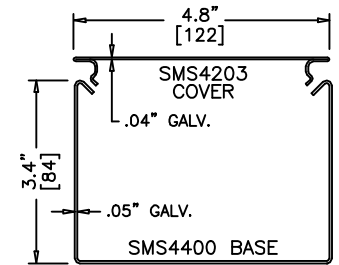

SMS4400 SERIES
 STEEL RACEWAY
 SECTION VIEW
 EACH ORDERED SEPARATELY
 SCALE: NONE

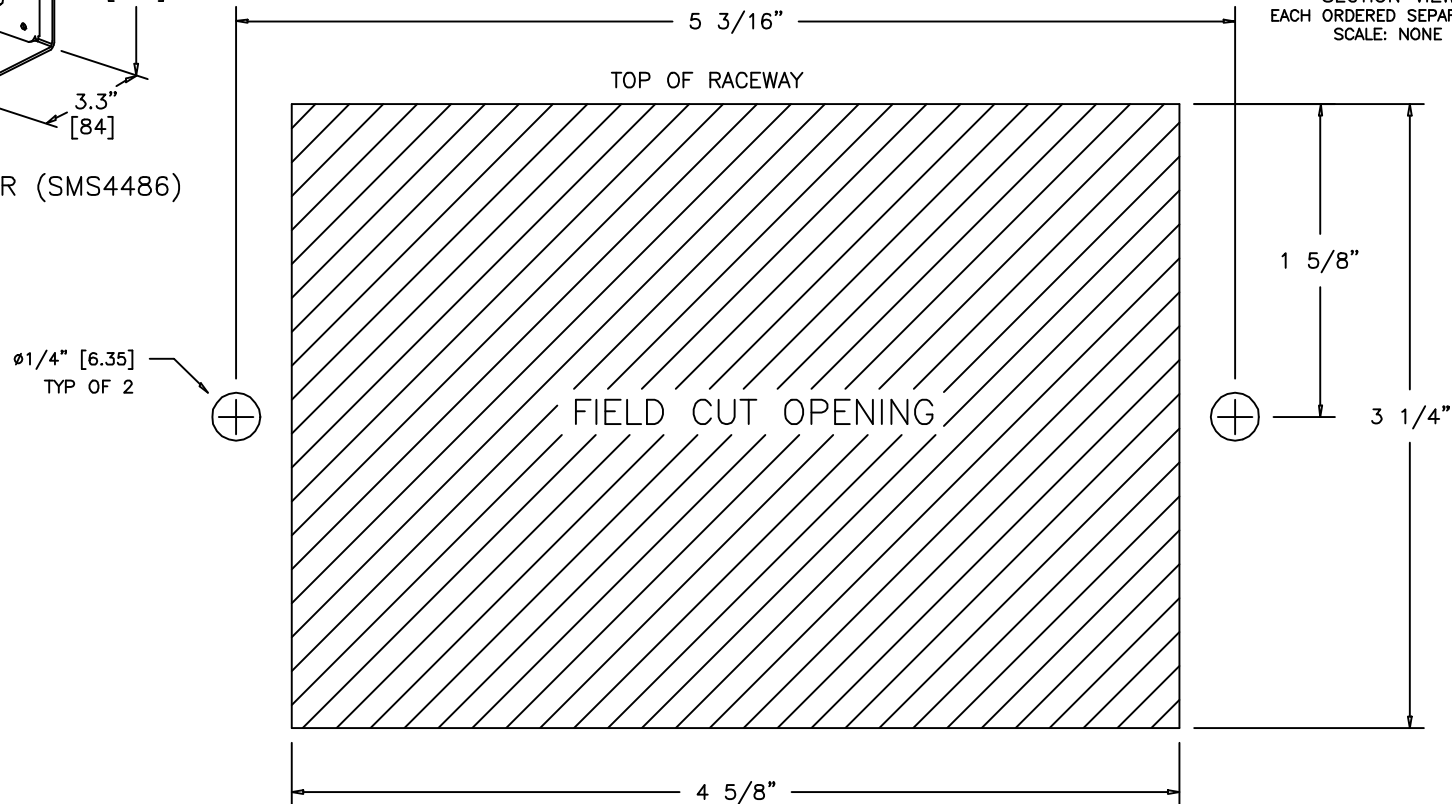

ENCLOSURE OR J-BOX OPENING TEMPLATE

SCALE: 1=1 FIELD CUT OPENING & DRILL MTG. HOLES IN ENCLOSURE OR J-BOX.



MONO-SYSTEMS, INC.
 UNIQUE CABLE DISTRIBUTION SOLUTIONS
 4 INTERNATIONAL DRIVE
 RYE BROOK, NEW YORK 10573
 PHONE: (914)-934-2075
 FAX: (914)-934-2190

CIRCUIT BREAKER HOUSING (SMS4490)

SCALE: NONE

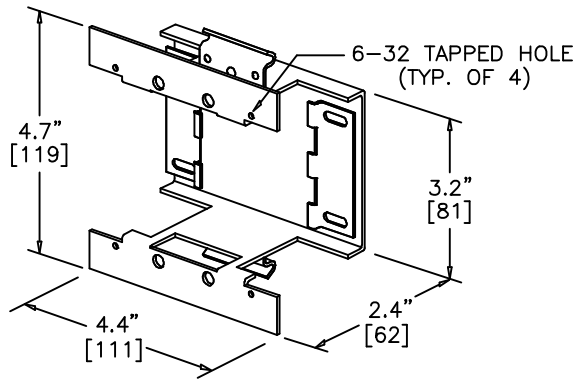

CIRCUIT BREAKER HOUSING (SMS4490)

FOR USE WITH 100A MAX BREAKERS
 G.E. - THQC & THHQ
 WESTINGHOUSE - QUICKLAG, C & QCH

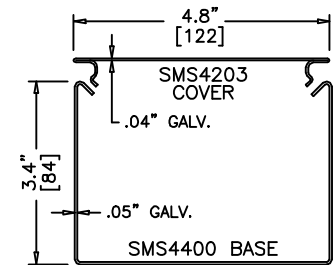

SMS4400 SERIES
 STEEL RACEWAY
 SECTION VIEW
 EACH ORDERED SEPARATELY
 SCALE: NONE

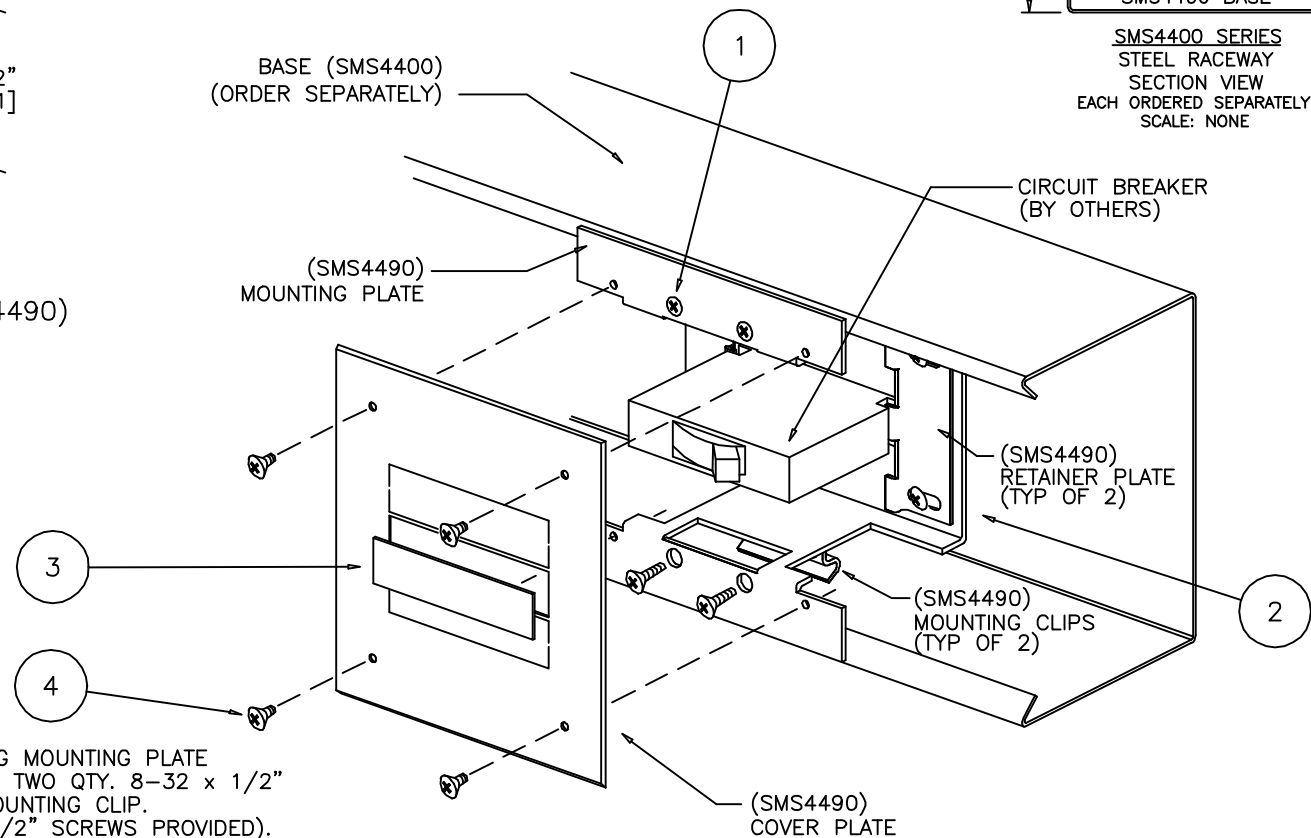

ASSEMBLY INSTRUCTIONS

1. SECURE THE CIRCUIT BREAKER HOUSING MOUNTING PLATE TO THE SMS4400 BASE SECTION USING TWO QTY. 8-32 x 1/2" FLAT HEAD SCREWS THROUGH EACH MOUNTING CLIP. (2 PLACES TOTAL - 4 QTY. 8-32 x 1/2" SCREWS PROVIDED).
2. SECURE THE CIRCUIT BREAKER (BY OTHERS) TO THE CIRCUIT BREAKER HOUSING USING 2 QTY. 8-32 x 3/16" PAN HEAD SCREWS BOLTS THROUGH EACH RETAINER PLATE. (2 PLACES TOTAL - 4 QTY. 8-32 x 3/16" SCREWS PROVIDED).
3. REMOVE DESIRED COVER PLATE KOs.
4. SECURE COVER PLATE TO MOUNTING PLATE USING 4 QTY. 6-32 x 1/8" FLAT HEAD FINISHED SCREWS (PROVIDED).
5. TERMINATE AND ENCLOSE ALL WIRING PER NEC AND LOCAL CODES.

FILENAME: 4490A.DWG



MONO-SYSTEMS, INC.
 UNIQUE CABLE DISTRIBUTION SOLUTIONS
 4 INTERNATIONAL DRIVE
 RYE BROOK, NEW YORK 10573
 PHONE: (914)-934-2075
 FAX: (914)-934-2190

DEEP DEVICE BOX (SMS44A4)

SCALE: NONE

AVAILABLE IN STANDARD GRAY OR IVORY
 (ADD "-I" SUFFIX TO SPECIFY IVORY)

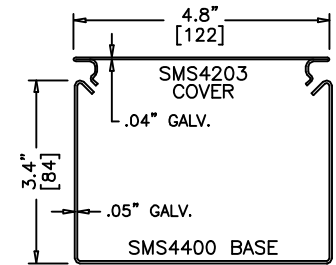

SMS4400 SERIES
STEEL RACEWAY
SECTION VIEW
 EACH ORDERED SEPARATELY
 SCALE: NONE

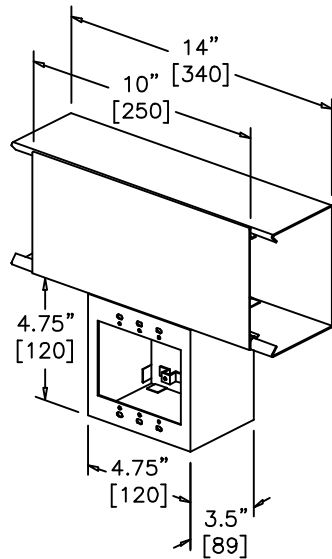

DEEP DEVICE BOX (SMS44A4)

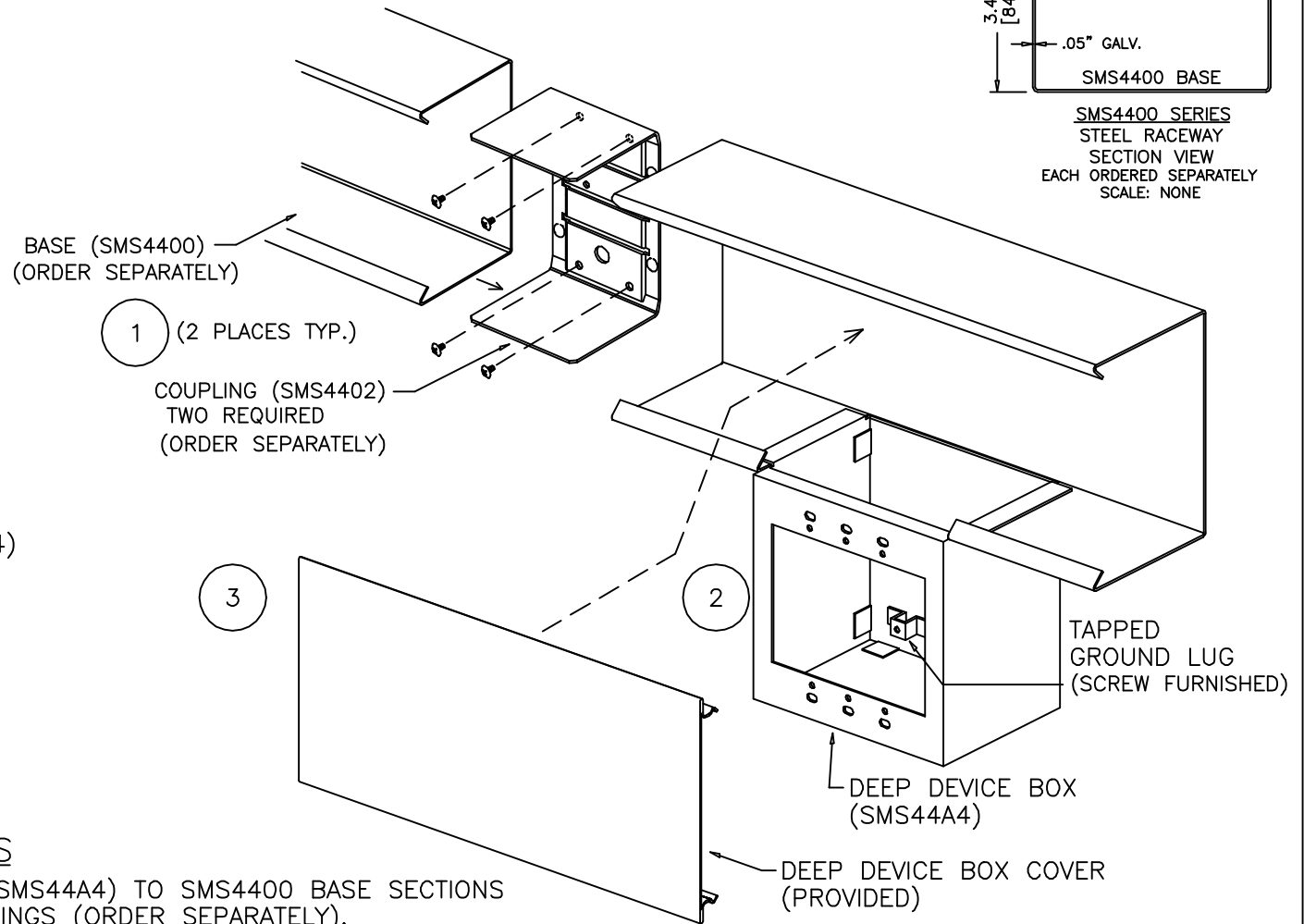

ASSEMBLY INSTRUCTIONS

1. ATTACH DEEP DEVICE BOX (SMS44A4) TO SMS4400 BASE SECTIONS USING TWO SMS4402 COUPLINGS (ORDER SEPARATELY).
2. INSTALL AND TERMINATE WIRING DEVICES AS PER NEC AND LOCAL CODES. INSTALL COMMERCIALY AVAILABLE DEVICE PLATE. (DEVICES, DEVICE PLATES AND DEVICE HARDWARE BY OTHERS)
3. SNAP PROVIDED COVER OVER SMS44A4 BOX RACEWAY OPENING.

FILENAME: 44A4A.DWG



MONO-SYSTEMS, INC.
UNIQUE CABLE DISTRIBUTION SOLUTIONS
 4 INTERNATIONAL DRIVE
 RYE BROOK, NEW YORK 10573
 PHONE: (914)-934-2075
 FAX: (914)-934-2190